

TREADWELL™

COMPLETE “Fit & Forget” SOLUTIONS

Sector Guide

RAIL INFRASTRUCTURE



ENGINEERING THE FUTURE IN COMPOSITES

www.treadwellgroup.global

Let Treadwell Help You Release the Power of Engineered Composites on Your Next Project

Corrosion Resistant



- Manufactured from premium isophthalic and vinyl ester resin systems.

Cost Savings

- Longer service life, less maintenance, and life cost savings as compared to other materials.
- Allows better and viable components into the associated framework.

High Strength

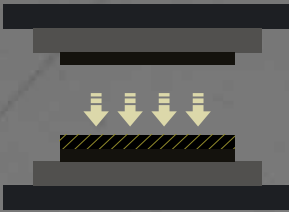

- Manufactured by automated pultrusion process.
- Utilises high glass-fibre content and results in unparalleled product consistency.
- Compression moulding and vacuum moulding processes are used.

Turnkey Solutions



- Pre-fabricated to eliminate field fabrication and make installation quick and easy.
- Solutions include all necessary accessories.

Durability



- Highly durable.
- Greater resistance to breaks and twists which ensure better longevity.
- Reduce the harmful effects of added tension on the surface and relieving the framework.

Customised System

- Our experienced technical team customises designs to meet project specific load requirements.

UV Protection



- Exterior coatings and stabilisers provide UV protection and ensure long service life.

Low Profile

- Aesthetically pleasing flat covers.
- Eliminate confined-entry issues.
- Provide protection for equipment located on top of the cover instead of below.

Light Weight



- Strength-to-weight properties of GRP reduce loads on tank walls and floors.
- Ease cover removability and installation.
- Can be transported anywhere easily and installed seamlessly.

No Dissimilar Metals



- Eliminates issues surrounding dissimilar metals

Contents

04	What You Get When You Work with Treadwell
05	Bespoke & Specialised Projects - Our Process Explained
06	Why Choose Treadwell?
07	EXduro™ GRP Cable Management Products
08	Treadwell EX-Series® GRP Grating
09	Case Study – Trackside GRP Grating
10	RailEX® ROUND Tubular Handrail
11	RailEX® ROUND Overview
12	RailEX® ROUND Stanchion Kits & Handrail Parts
13	Case Study – Rail Maintenance Facility GRP Handrail
14	ArchitEX™ Composite Structural GRP
15	ArchitEX™ GRP Profiles
16	Case Study – GRP Permanent Formwork
18	TreadSLAB® Panel Types Available
19	Case Study – TreadSLAB®
22	TREADSAFE™ Anti-Slip Safety Solutions
23	Case Study – Lilydale Metro Station Expansion Gap Covers
24	EX-Series® Industrial Composite Solutions
25	Case Study – Elevated Safety Access Platforms
26	Case Study – Emergency Egress Stairs & Refuge Platforms
27	Case Study – Signal Access Platform
28	Case Study – Bowen Mayne Yard
29	GRP Fencing & Screening Solutions
30	Case Study – GRP Screening
31	Case Study – GRP Fencing
33	Our Partners



Quality Policy

Quality is at the forefront of Treadwell's working practices. With over 15 years of manufacturing to the highest quality standards, Treadwell prides ourselves on our reputation for implementing strict quality control measures, and strives to supply products that surpass customers expectations. The company works on a policy of 'continuous improvement'.



Environment Policy

Treadwell is conscious of the impact it has on the environment and its associated responsibilities. The company is committed to ensuring its operations satisfy legal obligations and other responsibilities. Treadwell remains committed to sustainability.

Disclaimer: The information contained in this Treadwell design guide herein supplied is as a service to our customers and is intended to be used only as a general guide. It is not a substitute for proven engineering practices and designs.

What You Get When You Work with Treadwell

Specialised Online Tools

Conveniently located online, our selection tool allows users to fill in selection criteria based on each product brand we carry and will recommend a product suitable to your needs. Our product information has been imprinted on the tool to provide ease of outline and inspiration to architects, engineers, designers and other users. Users can also find all our product files in PDF, DWG, STEP etc. files to download for each of our products.

Visit our website at <https://treadwellgroup.uk/treadspeg> to try out these online specifier tools.



Friendly & Professional Design Support

Whether you're looking to upgrade or completely revamp your rail infrastructure assets, we can help support your design services across all stages of your project lifecycle. Our qualified and experienced engineering team have provided turnkey as well as purely design-based projects. With a knowledgeable team, we are able to provide solutions to fit your requirements.



Cutting Edge Technical Information

Treadwell has a LEAN manufacturing facility, approximately 4000m² under one roof. Our automated CNC equipment, including state-of-the-art 90,000 PSI waterjet cutting system and beam line ensures minimal material wastage, and as such, eliminates excessive costs. Our internal design engineering department is able to provide design expertise and sign off engineering in all states of Australia (RPEQ and NT certified), and an on-site Quality Assurance team to perform the necessary checks.



With a proven track record delivering large-scale projects across Oceania, we apply the same rigour and reliability to the UK market. Our long-standing partnerships with logistics providers, combined with hands-on fleet experience enable us to manage time-critical deliveries efficiently and consistently, meeting the expectations of UK clients.

Bespoke & Specialised Projects - Our Process Explained

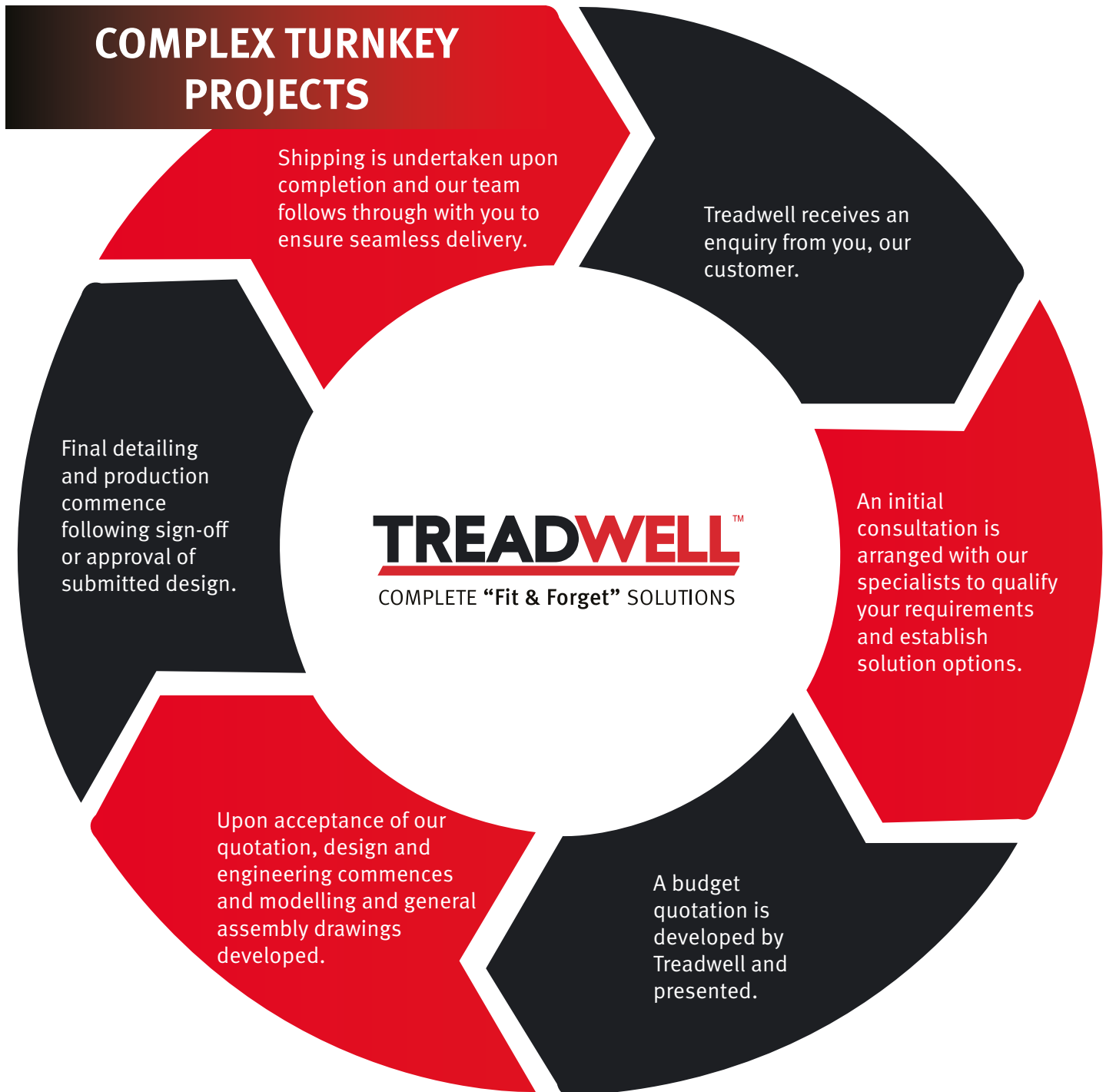

Why Choose Treadwell?

- 1 Our team of engineers are available to support your design requirements by providing technical expertise and specifications.
- 2 Our products are tested and meet relevant compliant codes where required.
- 3 We offer solutions based on practical calculations and data, providing the optimum products for your application.
- 4 We are an established name in Australia for providing durable and dependable GRP solutions.



EXduro™ Cable Ladders

For environments where corrosive elements play a crucial part in a material, Treadwell has developed its GRP cable ladders as a strong support solution as the alternative to metal cable ladders. Being lightweight, it allows for easier installation or onsite fabrication as well as giving the cable ladder a high strength to weight ratio.





EXduro™ fibreglass cable ladders has several other benefits that may be useful. It is both a UV resistant and fire retardant system. Transparent to RF frequencies and electrically non-conductive are other positives it can bring to any design.

EXduro™ fibreglass cable ladders are also a cost competitive, performance proven alternative to metal systems for that corrosive/chemical environment to run your electrical cable and instrumentation pipe work. With minimal to no ongoing maintenance, Treadwell's system is supplied with both GRP and stainless steel fasteners to suit your application.

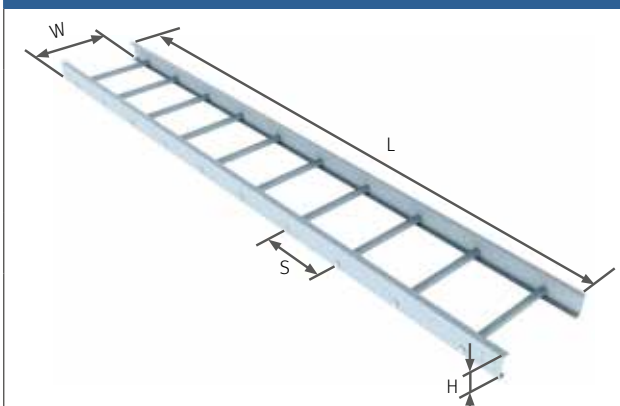
F-EXD-CL-C(H)(W)-(R)(S)-(RS)(C)-(L)						
Side Rail Height (H)	Width (W)	Rung Type (RT)	Rung Spacing (S)	Resin (RS)	Colour (C)	Length (L)
50mm (050)	150mm (150)	Standard Rung (S)	150mm (150)	Standard Polyester (SI)	Light Grey (LG)	3m (1) N
75mm (075)	300mm (300)	Marine Rung (M)	250mm (250)	Standard Vinylester (SV)	Custom Colour (CC)	6m (2) C
100mm (100)	450mm (450)		300mm (300)	Conductive Polyester (CI)		
150mm (150)	600mm (600)		450mm (450)	Conductive Vinylester (CV)		
200mm (200)	750mm(750)		Halogen free Polyester (HI)			
	900mm (900)		Halogen free Vinylester (HV)			
				Halogen free Low Smoke Plus (HF)		

EXduro™ Cable Ladder



Straight splice plate	90 Vertical splice plate
	
Adjustable vertical splice plate	Adjustable Horizontal splice plate
	

Cable Ladder Splice Plates

Our splice plates are available in both horizontal and vertical degree sections. We also offer the accompanying accessories separately. We construct both flat and peaked covers. These plates are non-conductive and do not react on electric and magnetic fields.

Treadwell EX-Series® GRP Grating

Treadwell EX-Series® Glass Reinforced Plastic (GRP) grating products are recommended for areas where physical properties are paramount to design and longevity. Treadwell offers an extensive range of GRP grating products, two of which are highly utilised in the rail industry. There are key differences to take note of. The information below outlines the key differences and the ideal scenarios in which the different types of grating are to be utilised.

GratEX® Moulded GRP Grating

The perfect solution for areas where excessive amounts of penetrations (i.e. for piping) call for traditional uni-directional spanning products. This greatly increases the costs when using traditional materials, like steel. GRP grating maintains strength and integrity even with multiple penetration cut outs, while keeping costs low.

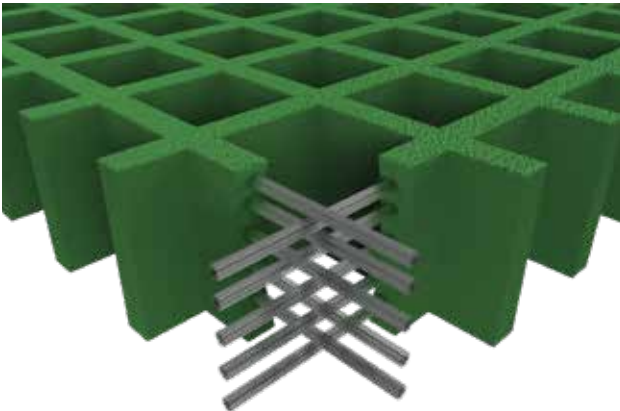

GridEX® Pultruded GRP Grating

The ultimate choice for areas where extremely high loadings, or larger spans present a challenge. Such applications include wide walkways, or where equipment needs to be installed on top of grating.

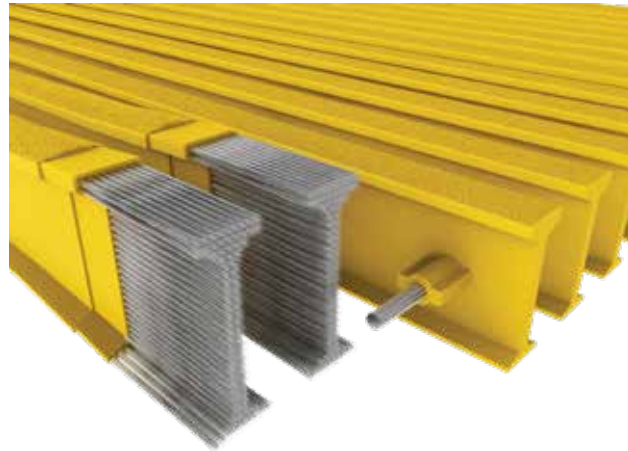

Please consult our EX-Series® Grating Product Guide for more information.

Case Study – Trackside GRP Grating



PROJECT INFORMATION	
Project Category:	Utilities Infrastructure
Treadwell Products:	EX-Series® GratEX® GRP Grating

Treadwell's GratEX® moulded GRP grating is a high strength, single piece construction mesh panel product. Treadwell offers both standard panel sizes as well as the option of custom panels made to order from your drawings, or alternatively, drawings provided by Treadwell's drafting department.

Cost-effective GratEX® panels allow for effective on-site fabrication/trimming whilst ensuring that wastage is minimised. Load-bearing bars in both directions allow for use without continuous side support and contribute to cost effectiveness. GratEX® offers all the benefits available with grating made from other materials, plus a host of superior benefits unequalled by steel or other metal alternatives.

Treadwell GratEX® moulded GRP Grating comes in square, mini, micro mesh and solid surface panels.



Treadwell's Solution:

- 1

Treadwell's EX-Series® GratEX® GRP grating has a unique surface finishing system which ensures UV stability in exposed applications, directly eliminating the need for costly surface treatment.

- 2

EX-Series® GratEX® is corrosion resistant and can be constructed with an impregnated anti-slip surface for optimal user safety.

- 3

GRP has naturally low thermal and electrical conductivity.

- 4

GRP is lightweight, presenting multiple cost savings in logistics and transportation, and can be installed by hand, minimising the need for heavy machinery.

- 5

GRP is simply fabricated and modified on site. This means there is no need for any hot works permit.

What is RailEX® ROUND Tubular Handrail?

Treadwell's RailEX® ROUND Tubular Handrail is an industrial rated composite handrail system which combines strength, durability and versatility meaning the system is ideal for use in numerous applications in a vast range of industries. Treadwell can supply RailEX® as either components or as fabricated handrail panels ready for installation.

Smart Transposable Designs

Unlike traditionally welded alternatives, Treadwell GRP handrail system dispenses the need for drafting, engineering and onsite fabrication while minimising installation costs. Treadwell's safety handrail systems can be adapted or extended with additional components, or cut to size onsite. Pre-engineered kits are supplied as a series of components with simple assembly instructions. With our clients in mind, Treadwell aims to minimise the cost of maintenance and repairs, and damaged components easily with readily available parts and stock.

Simple Zero Weld Assembly

As an added benefit, fibreglass handrail kits are assembled using a simple, zero weld construction method; reducing the chances for corrosion activation. Treadwell's RailEX® designs and fittings effectively eliminate the need for specialist trades, hot works permits, fire spotters and welding protection to finished surfaces. Our selection of GRP increases safety conditions for installers by eliminating toxic fumes, welding in wet areas and fire risk hazards.

Developed by Treadwell with the input of designers, and plan operators, this system offers you all benefits of traditional guardrail systems without the inherent problems - corrosion, welding and hot works permits for onsite modifications. This unique system is a first to be tested and conform with Australian Standards AS 1657. RailEX® is the 'Fit & Forget' handrail system.



This product conforms to AS1657



RailEX® Features and Benefits vs. Traditional Alternatives

	RailEX®	Stainless Steel	Galvanised Steel	Aluminium	Timber
Chemical Resistance	●●●●●	●●●●	●	●●●	●●●●
Strength	●●●●●	●●●●●	●●●●●	●●●●●	●●
Lightweight	●●●●●	●	●	●●●●●	●●
Electrical Resistance	●●●●●	●	●	●●●●●	●●●●●

Materials of Construction

RailEX® GRP handrail is constructed from fibreglass rovings combined with a blend of thermosetting resin systems. All of the resins used in the production of EX-Series® products contain UV inhibitors and fire retardant additives.



RailEX[®] ROUND Overview

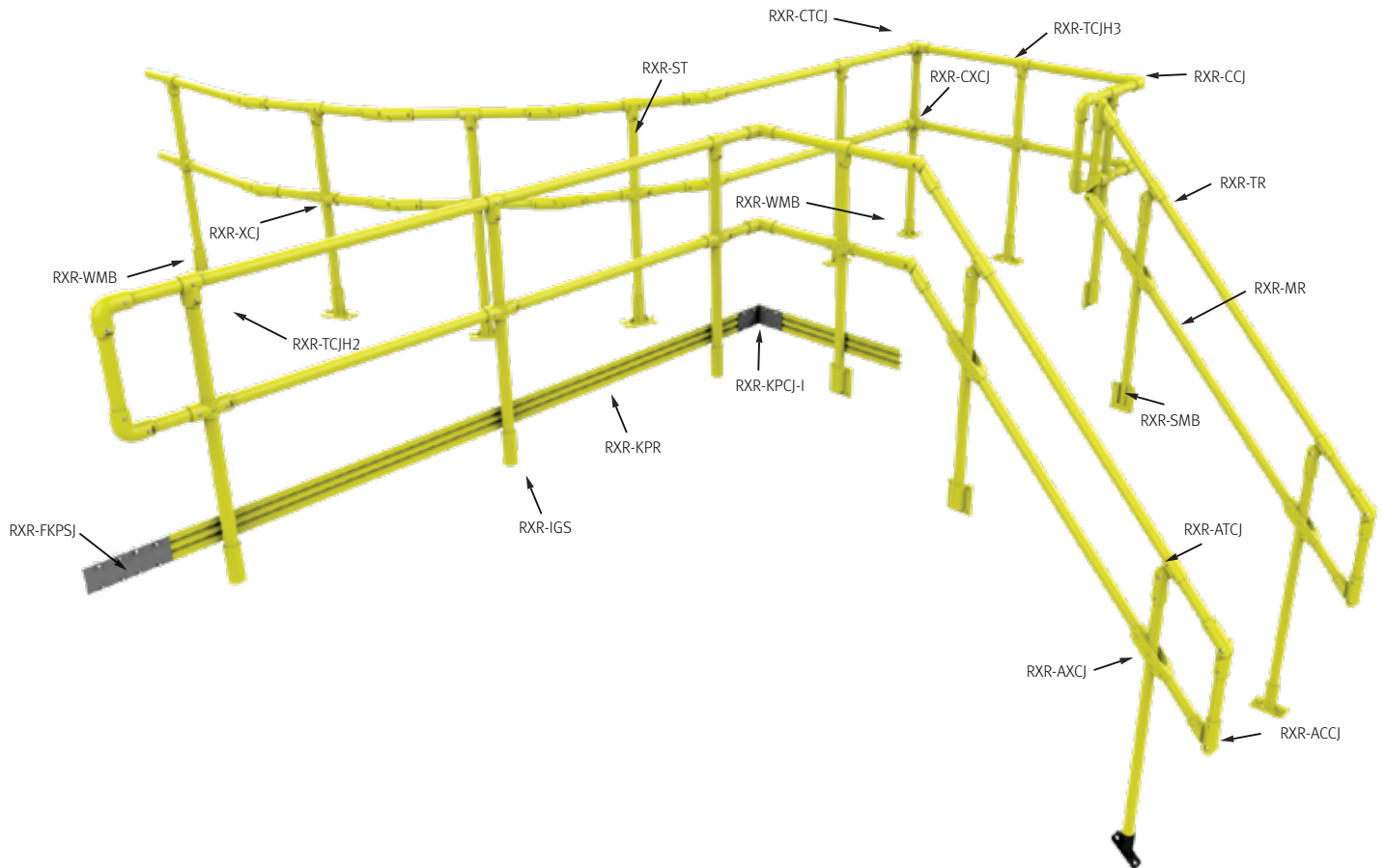









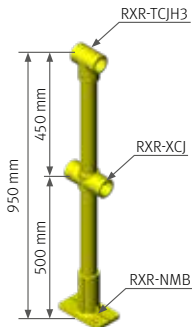
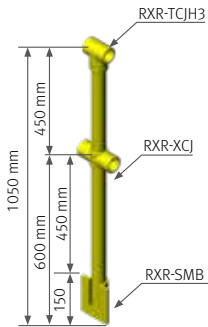
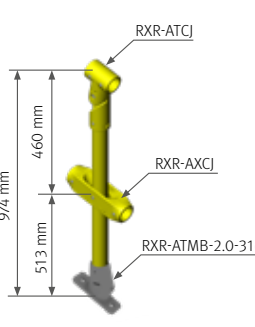
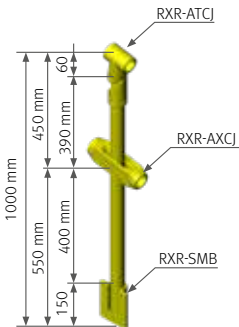



Please consult our RailEX[®] Handrail Product Guide for more information.

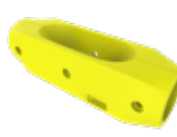

RailEX® ROUND Stanchion Kits & Handrail Parts

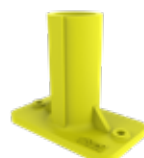
Treadwell has created options of RailEX® handrail stanchion kits. This ensures that all the required parts are included, making for easy planning and installation. Please note that the list below is just a selection of our most popular handrail assemblies. For a more comprehensive selection, please consult our RailEX® Product Guide .

RXR-SN-VY-K	RXR-SS-VY-K	RXR-AA-VY-K	RXR-AS-VY-K
<p>RailEX® ROUND Stanchion Sales Kit, Standard Stanchion with Narrow Mounting Bracket, V-Series® Safety Yellow, including Stainless Steel Fasteners.</p>  <p>NOTE: Assembly excludes fasteners to connect to structure.</p>	<p>RailEX® ROUND Stanchion Sales Kit, Standard Stanchion with Side Mounting Bracket, V-Series® Safety Yellow, including Stainless Steel Fasteners.</p>  <p>NOTE: Assembly excludes fasteners to connect to structure.</p>	<p>RailEX® ROUND Stanchion Sales Kit, Adjustable Stanchion with Angled Round Top Mount Bracket, V-Series® Safety Yellow, including Stainless Steel Fasteners.</p>  <p>NOTE: Assembly excludes fasteners to connect to structure.</p>	<p>RailEX® ROUND Stanchion Sales Kit, Adjustable Stanchion with Side Mounting Bracket, V-Series® Safety Yellow, including Stainless Steel Fasteners.</p>  <p>NOTE: Assembly excludes fasteners to connect to structure.</p>
 <p>RXR-CC Standard ROUND Fibreglass 90° Corner Connection Joint</p>	 <p>RXR-XCJ Standard ROUND Fibreglass Cross Connection Joint</p>	 <p>RXR-TCJH2 Standard ROUND Vertical Fibreglass Connection Joint</p>	
 <p>RXR-TCJH3 Standard ROUND Horizontal Fibreglass Tee Connection Joint (three holes)</p>	 <p>RXR-TRJ Standard ROUND Fibreglass Top Rail Joiner</p>	 <p>RXR-ACCJ Adjustable ROUND Fibreglass Corner Joint</p>	
 <p>RXR-AXCJ Adjustable ROUND Fibreglass Cross Connection Joint</p>	 <p>RXR-ATCJ Adjustable ROUND Fibreglass Tee Connection Joint</p>	 <p>Standard Stainless Steel Driver Kit M6 Type with Trilobular Head</p>	
 <p>RXR-SMB Standard ROUND Fibreglass Side Mounting Bracket</p>	 <p>RXR-NMB Standard ROUND Fibreglass Narrow Mounting Bracket</p>	 <p>Standard Stainless Steel Fastener Kit M6 with Trilobular Head (stock item)</p>	 <p>Standard Stainless Steel Fastener Kit M10 (stock item)</p>

Case Study – Rail Maintenance Facility GRP Handrail



PROJECT INFORMATION	
Project Category:	Utilities Infrastructure
Scope of Work:	Supply RailEX® GRP Solution
Treadwell Products:	EX-Series® RailEX® ROUND GRP Handrail

The RailEX® GRP handrail system is a patented industrial rated product that is noted for its durability, strength, and versatility. Our RailEX® products can be delivered as components or as prefabricated systems for immediate installation.

Ideal for those long straight runs or cornered barrier areas, Treadwell makes it easy to set up and install your own round tube GRP handrail system. With the thick-walled design of the round tube, Treadwell offers a strong yet simple handrail system that is made easy for installation.

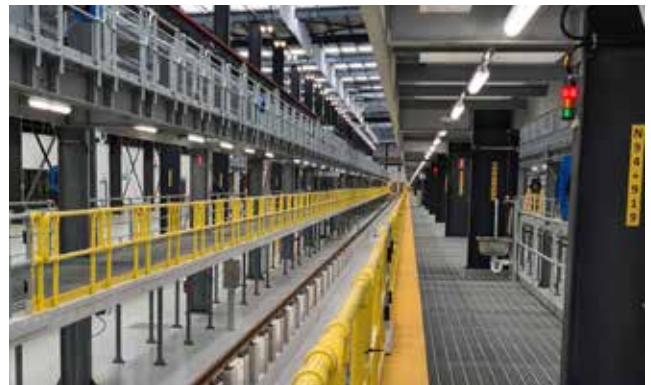

Treadwell's Solution:

- 1

Treadwell's RailEX® GRP handrails have a unique finishing which eliminates the need for painting and ensures that fibres are not exposed, keeping hands safe.

- 2

A key concern in rail environment is arc potential. GRP is naturally low in electrical conductivity, making it an ideal solution over traditional materials.

- 3

The lightweight nature of GRP enables operators to remove sections of the handrails as required for easy access. These are also easily reinstalled with hand tools.

ArchitEX™
Structural Profiles & Structures

Composite Structural GRP

The ArchitEX™ range of products comprises of a variety of structural profiles that are manufactured from Glass Reinforced Plastic (GRP). It is through continual research and development that this wide range of fibreglass sections, beams, and profiles are fabricated consistently to ensure satisfactory results even in challenging structural conditions.

The GRP beams, columns and associated sections are produced from high quality GRP material, which makes structures strong as well as rewarding. Durable construction GRP such as fibreglass sections and beams enhances the strength of the entire framework as well as infrastructure. Both fibreglass beams and sections are specifically designed to endure all sorts of environmental inconsistencies.

Scope of Shapes

Easy integration to various parts due to the capability to essentially shape any item with a constant cross section which can be pultruded.

Composite Design Engineering

A standard shape customised into a pultrusion by modifying the resin or reinforcement to achieve a particular customer need.

Optimising Resins

Standard resins can be modified or special resins can be used to maximise performance of the pultrusion in challenging environments, such as those found in high temperature or extremely corrosive areas. Typical resins include polyesters, vinylesters, PVC, epoxies, phenolics, urethanes and blends.

Choice of Reinforcements

The type, form, placement and quantity of reinforcements can be customised to optimise economy, develop ascribed strength and create or enhance other physical characteristics of a pultruded part. Typical reinforcements used include glass or carbon fibres in multifilament strands, mat (long fibres held together with a resinous binder) or stitched fabrics.

Core Materials Options

Treadwell provides a range of core material options with comprehensive experience in pultruding over various materials including foam, balsa, polyethylene and aluminium.

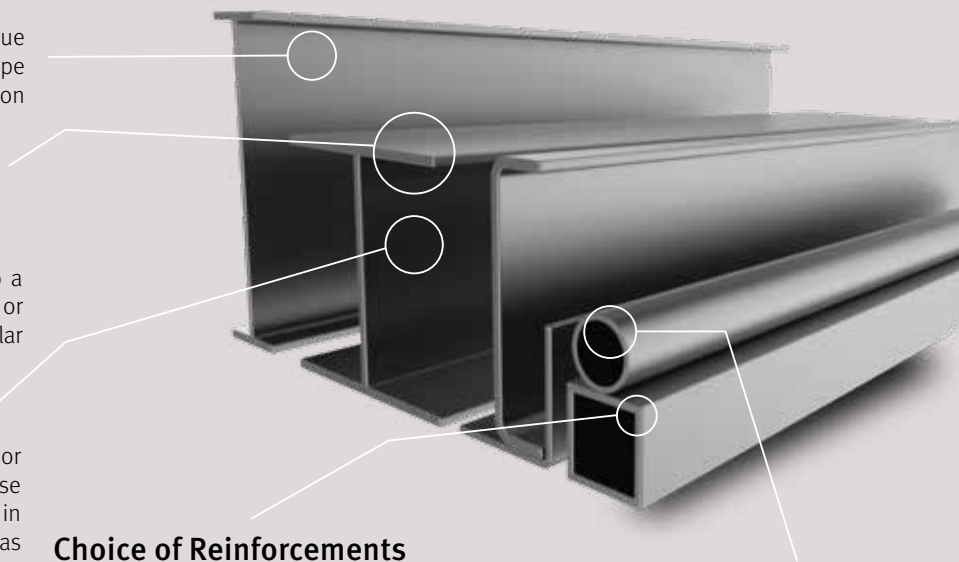













Structural Design & Analysis

Our experienced team of engineers and designers can help conceptualise your design and maximise all GRP structural components to offer the most cost effective and simplest solution.



ArchitEX™ GRP Profiles

ArchitEX™ Range		
C Channel	I-Beam	WF-Beam
		
Double Web Beam	Unequal Leg Angle	Equal Leg Angle
		
Square Hollow Section	Rectangular Hollow Section	Circular Hollow Section
		
Circular Round Bar	Solid Bars	Embedment Angle
		

Please consult our ArchitEX™ Structural Product Guide for more information.



Case Study – GRP Permanent Formwork



PROJECT INFORMATION	
Project Category:	Rail Infrastructure
Scope of Work:	To provide sacrificial formwork
Treadwell Products:	ArchitEX™ GRP custom structural sections.

Treadwell was contacted by an NSW Alliance to provide a sacrificial formwork that could be installed on top of the existing platform. This then needed to be backfilled with concrete. In addition to supplying the GRP formwork itself, Treadwell was also able to provide the engineering certification required for the unequal leg angle to be used for the project.



Treadwell's Solution:

- 1 Treadwell's high performance ArchitEX™ premium grade unequal leg angle profile was utilised.
- 2 Engineered corrosion resistant fibreglass resins.
- 3 Custom manufactured tooling designed fit for purpose to ensure that all concrete is encapsulated.
- 4 GRP is simply fabricated and modified on site. This means there is no need for any hot works permit.
- 5 Being lightweight and easy to install, GRP is very manageable during construction.
- 6 Given the nature of GRP, any system utilising it is virtually maintenance free, keeping maintenance costs to a minimum.



Arncliffe

Sydney, New South Wales - Arncliffe Train Station

TreadSLAB® Panel Types Available

TreadSLAB®

TreadSLAB® is an immensely versatile profile which combines lightweight and inherent strength to provide a durable product with a variety of surface textures and a customisable range of colours. Through the selection of the appropriate resin system, the user can create components that will meet the most demanding of specifications.

Pultruded through a die, TreadSLAB® outperforms with an impressive strength to weight ratio to produce a composite flooring structure that is strong, durable, corrosion resistant and boasts low maintenance on an anti-slip surface.

Benefits

- High strength
- Light weight
- Dimensional stability
- Corrosion, chemical, electrical resistance
- Low tooling/installation cost
- Long life
- Favourable performance/lifecycle cost basis versus traditional materials

TreadSLAB® easily outperforms traditional materials in terms of performance/ lifecycle costs.

Part: TreadSLAB® Medium Duty Panel

Part Number: **ARX-SL040**

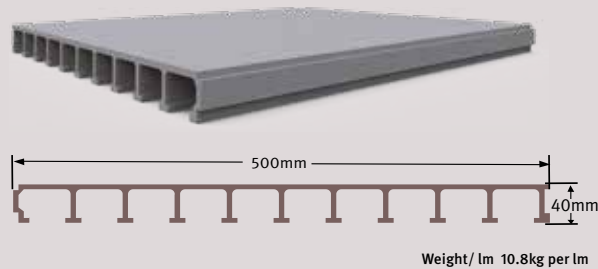

Part: TreadSLAB® Heavy Duty Panel

Part Number: **ARX-SL100**

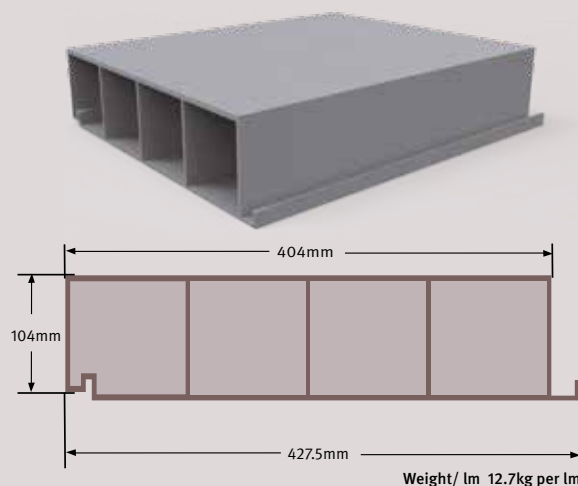

Case Study – TreadSLAB®



PROJECT INFORMATION	
Project Category:	Rail Infrastructure
Scope of Work:	Supply GRP decking
Treadwell Products:	TreadSLAB® GRP panels

As part of the rail infrastructure project in Victoria, a brand-new Rosanna rail station was constructed. Built over six weeks, with around 1,000 people working around the clock, this station was operational months ahead of schedule. As a result of this new station, traffic bottlenecks have been greatly reduced, and motorists have been able to travel freely and safely.

Treadwell was engaged to provide the GRP panels used in the passenger walkways and platforms.



Treadwell's Solution:

- 1 Treadwell's TreadSLAB® GRP panels are constructed with an anti-slip surface, with corrosion resistant properties, making it ideal for this outdoor application.
- 2 These panels are lightweight for easy installation and isolated panels can be removed for maintenance requirements.
- 3 TreadSLAB® panels are constructed to withstand high weight loading.
- 4 GRP is simply fabricated and modified on site. This means there is no need for any hot works permit.
- 5 Being lightweight and easy to install, GRP is very manageable during construction.
- 6 Given the nature of GRP, any system utilising it is virtually maintenance free, keeping maintenance costs to a minimum.

Case Study – TreadSLAB®



PROJECT INFORMATION	
Project Category:	Rail Infrastructure
Scope of Work:	Design & supply anti-slip lightweight walkway access
Treadwell Products:	TreadSLAB® GRP Panels

Treadwell was contacted to assist with providing a product that could be used as a lightweight anti-slip solution as a walking surface on the temporary walkway gantry at Martin Place Sydney. The walkway gantry runs between Elizabeth St. and Castlereagh St. To date, it has been installed for over 12 months and has a daily pedestrian traffic volume exceeding 36,000 people.



Treadwell's Solution:

- 1 Treadwell's high performance EcoEX™ SureLine® HD panels are manufactured from premium grade, corrosion-resistant fibreglass resins.
- 2 The panels for this project were designed and customised to meet live load requirements.
- 3 GRP is simply fabricated and modified on site. This means there is no need for any hot works permit.
- 4 Being lightweight and easy to install, GRP is very manageable during construction.
- 5 Given the nature of GRP, any system utilising it is virtually maintenance free, thus keeping maintenance costs as low as possible.

Case Study – TreadSLAB®



PROJECT INFORMATION	
Project Category:	Rail Infrastructure
Treadwell Products:	TreadSLAB® GRP Panels

TreadSLAB® is an immensely versatile profile which combines lightweight and inherent strength to provide a durable product with a variety of surface textures and a customisable range of colours. Through the selection of the appropriate resin system, the user can create components that will meet the most demanding of specifications.

Pultruded through a die, TreadSLAB® outperforms with an impressive strength to weight ratio to produce a composite flooring structure that is strong, durable, corrosion resistant and boasts low maintenance on an anti-slip surface.

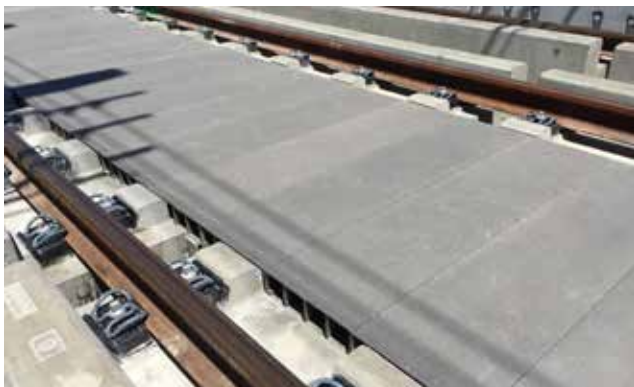

Treadwell's Solution:

- 1 TreadSLAB® Heavy Duty GRP panels are constructed in a way that allows for easy removal of panels whenever access is required.
- 2 TreadSLAB® GRP panels are constructed with an anti-slip surface for optimal user safety.

Please consult our ArchiTEX™ Interlocking & Decking Product Guide for more information.



TREADSAFE™
Industrial Anti-Slip Solutions

Anti-Slip Safety Solutions

TREADSAFE™ is Treadwell's selection of pre-manufactured and ready made for installation anti-slip products for harsh environments.

Fabricated from GRP composites, anti-slip decks and rung covers are easy to install over existing stairs to create the toughest and most dependable anti-slip surface available.

Proven in many applications, the series is available in various styles and colours to suit any environment.

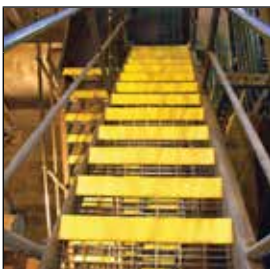

StairSAFE™

Long wearing, anti-corrosive, non-slip nosing designed to re-profile the leading edge of any step are the characteristics of StairSAFE™.



CableSAFE™

CableSAFE™ creates a safe walkway over exposed pipes, cables, wires and conduit. With a durable anti-slip surface, CableSAFE™ provides a safety bridge for foot traffic over these areas, avoiding slips, trips and falls.



RungSAFE™

The abrasive grit surface eliminates the very high possibility of slips from access ladders, avoiding serious ramifications. The surface, while ideal for the negation of slip issues, has been developed so as not to damage bare skin.

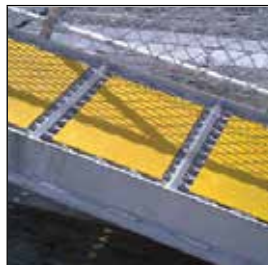

DeckSAFE™

DeckSAFE™ is the ultimate solution for slippery ramps, decks, catwalks and landings. Designed to reduce the risk of slips, trips and falls in areas where oil, water and other forms of liquids are present, DeckSAFE™ greatly reduces risks.

EASY INSTALLATION

Heavy duty industrial fixings for all applications. Surface for rungs normally applied by using a polyurethane adhesive glue system.



OPTIONAL DEPTH AND LENGTH

Available in four standard depths, 50mm, 75mm, 100mm and 300mm. Custom depths are also available up to 300mm. Available in any length up to 3,250mm.

SAFETY

Heavy duty grit layer provides an ideal anti-slip surface; likewise, safety yellow offers enhanced visibility.

CHEMICAL RESISTANT

Designed to handle most chemicals. Please refer to our Chemical Resistance Guide, found in our TREADSAFE™ Product Guide.

ZERO TRIP RISK

Smooth bullnose, sloped on an 85° inclined plane ensures no trip risk is posed.

ROBUST CONSTRUCTION

Specially formulated resin systems and metallic available on request.

Case Study – Lilydale Metro Station Expansion Gap Covers



PROJECT INFORMATION	
Project Category:	Rail Infrastructure
Scope of Work:	Supply GRP Expansion Gap Cover Plates
Treadwell Products:	TREADSAFE™ DeckSAFE® GRP anti-slip deck plating

Melbourne, Victoria – As part of the Level Crossing Removal Project (LXRP), the level crossing at Lilydale was removed, and a new elevated station was built. This project was established to improve safety, reduce traffic congestion, improve travel time reliability and increase train capacity on the rail network. With the construction of this new station, expansion gap covers needed to be installed on the train station platform. Treadwell was specified to supply these covers.

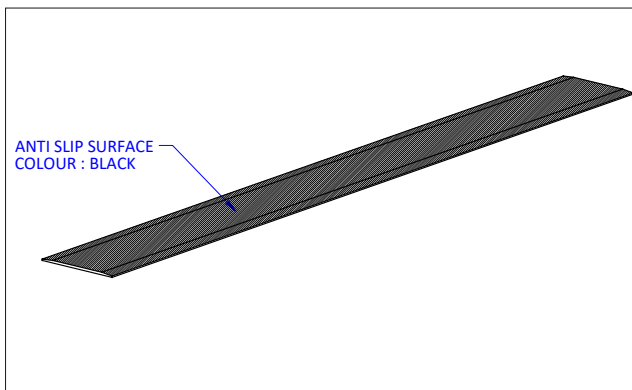

Treadwell's Solution:

- 1

DeckSAFE® GRP decking of a suitable resin system was specified for this application.

- 2

DeckSAFE® is constructed with an impregnated anti-slip grit surface. This ensures a long-wearing and durable anti-slip surface.

- 3

Being lightweight and easy to install, GRP is very manageable during construction.

- 4

Given the nature of GRP, any system utilising it is virtually maintenance free, keeping maintenance costs to a minimum.

What is EX-Series® Industrial Composite Solutions?

A designed composite structural and access solution featuring a combination of our GRP products.

These access structures are easily installed in elevated, remote, indoor or outdoor locations, and possess corrosion resistant and low electrical conductivity properties.



FIXED STAIRCASES

An GRP solution featuring a combination of ArchitEX™ structural profiles, EX-Series® grating and stair treads, and RailEX® handrails. Built to withstand corrosive indoor and outdoor environments.

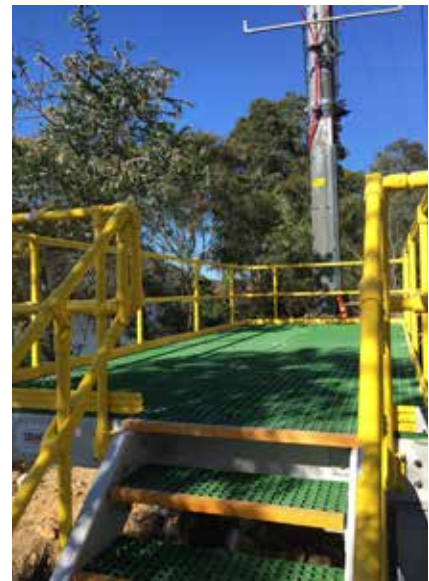

FIXED ACCESS PLATFORMS

These can be customised to the span required for its purpose. Being naturally non-conductive, GRP is a cost-effective and long-lasting solution for electrically sensitive environments.



FIXED STEPOVERS

All GratEX® and MoultrEX® premium and standard Stair Tread options are moulded with the solid leading-edge nosing as joint single stage component. This increases the rigor and sturdiness of the entire leading edge ensuring dependable performance in high traffic situations. All the treads with abrasive leading-edge nosings are manufactured to conform to AS 1657 – 2018.



RAIL PLATFORMS

Treadwell's TreadSLAB® GRP panels are constructed with an anti-slip surface and corrosion resistant properties. This maintains optimal user safety. Panels can also be customised according to load requirements.

Case Study – Elevated Safety Access Platforms



PROJECT INFORMATION	
Project Category:	Rail Infrastructure
Scope of Work:	Design and supply safety platforms
Treadwell Products:	EX-Series® GratEX® GRP Square Mesh Grating & Stair Treads ArchitEX™ GRP Structural Profiles RailEX® ROUND GRP Handrails

Wollongong, New South Wales – The NSW Government commenced the More Trains More Services (MTMS) program with an objective to modernise the rail network, offering more frequent train services to reduce wait times and crowding.

As part of the program, the NSW Government invested in new rolling stock which brought about the need to expand stabling yard facilities for storage and cleaning of the additional trains.

Treadwell was engaged by the project delivery contractor to design, fabricate and install non-conductive, non-slip and corrosion-resistant access platforms, known as ESAPs (Elevated Safe Access Platforms) to allow personnel safe and easy access to the trains for cleaning and other maintenance requirements.

Treadwell’s composite materials are lightweight and non-conductive, allowing for simple install without heavy equipment and the elimination of earthing and bonding requirements which was a key benefit to the timely and successful completion of the project.



Treadwell's Solution:

- 1 Treadwell’s GRP products are constructed from premium resin systems that include corrosion resistant properties and UV inhibitors.
- 2 GRP is naturally non-electrical and non-thermal conductive.
- 3 Treadwell’s GratEX® GRP grating has an impregnated grit surface which provides optimal slip resistance that meets the relevant Australian standards.
- 4 Being lightweight, heavy machinery is not required for installation.
- 5 GRP is simply fabricated and modified on site. This means there is no need for any hot works permit.
- 6 GRP is simply fabricated and modified on site. This means there is no need for any hot works permit.

Case Study – Emergency Egress Stairs & Refuge Platforms



PROJECT INFORMATION	
Project Category:	Rail Infrastructure
Scope of work:	Design & supply GRP stair system
Treadwell Products:	EX-Series® GratEX® GRP Stair Treads ArchitEX™ GRP Flat Plates

Melbourne’s busiest rail line underwent a transformation that saw the removal of nine dangerous and congested level crossings, to be replaced by elevated rail lines. As part of these new structures, emergency ingress and egress stairs, and refuge platforms were installed for staff safety.

All GratEX® and MoultrEX® premium and standard Stair Tread options are moulded with the solid leading edge nosing as joint single stage component. This increases the rigor and sturdiness of the entire leading edge ensuring dependable performance in high traffic situations. All the treads with abrasive leading edge nosings are manufactured to conform to AS 1657 - 2018.



Treadwell's Solution:

- 1

EX-Series® GratEX® GRP Stair Treads are corrosion resistant, and are constructed and remain robust even under constant outdoor exposure.

- 2

EX-Series® GratEX® GRP stair treads have an anti-slip surface for user safety.

- 3

Stair treads can be prefabricated in our factory, using flat plates as the structural support. This enables the stairs to be easily removed or installed and fastened based on requirements.

Case Study – Signal Access Platform



PROJECT INFORMATION	
Project Category:	Signal Access Platform
Scope of Work:	Fully design, engineer and supply EX-Series® GRP solution
Treadwell Products:	EX-Series® GratEX® GRP Square Mesh Grating EX-Series® RailEX® ROUND GRP Handrails ArchitEX™ GRP Structural Profiles

This train station located in New South Wales is off the beaten track, set in an idyllic location. Famously known for not being accessible via roads, this station is small and serves a handful of commuters and holiday home owners. As part of a maintenance and upgrade effort, a signal access platform needed to be installed along the train route.

Treadwell was engaged to design, engineer and supply the GRP products for this project.



Treadwell's Solution:

- 1

EX-Series® GratEX® GRP grating is designed to be high strength, and made as a single piece construction mesh panel. It is constructed from high-grade resin systems and provides superior non-conductivity.

- 2

Made with an anti-slip surface, it is hardwearing and tested to Australian standards.

- 3

GRP can be simply fabricated and modified on site. This makes any variance on task easily adapted to, especially in remote locations.

- 4

ArchitEX™ GRP Structural Profiles are constructed from a pultrusion process encompassing resin formulas and glass fibre products that create a strong, lightweight and durable product.

- 5

Treadwell's GRP products are RF transparent and has low thermal and electrical conductivity, ensuring user safety.

Case Study – Bowen Mayne Yard



PROJECT INFORMATION	
Project Category:	Rail Infrastructure
Scope of Work:	Supply GRP grating and handrails
Treadwell Products:	EX-Series® GRP Solution EX-Series® GratEX® GRP Square Mesh RailEX® ROUND GRP Handrails

Bowen Hills, Queensland – Established in the 1910’s, Mayne Yard in Bowen Hills railway station is the main stabling and maintenance precinct for Queensland’s daily network operations. To support their network growth, Mayne Yard is currently undergoing expansion upgrades in their precinct. These upgrades will support the network operations and optimize the benefits of Cross River Rail once it becomes operational.

As part of this upgrade, Treadwell was engaged to supply the GRP products needed for the expansion upgrade.



Treadwell's Solution:

- 1 Treadwell GRP is naturally non-electrical and non-thermal conductive.
- 2 Treadwell’s EX-Series® GratEX® GRP grating has an impregnated grit surface which provides optimal slip resistance that meets the relevant Australian standards.
- 3 RailEX® ROUND GRP handrails are constructed with an integrated protective coat that prevents delamination.
- 4 Being lightweight and easy to install, GRP can be installed with hand tools, without the need for heavy machinery.
- 5 GRP is simply fabricated and modified on site. This means there is no need for any hot works permit.
- 6 Given the nature of GRP, any system utilising it is virtually maintenance free, keeping maintenance costs to a minimum.

What is Treadwell Fencing & Screening Solutions?

Treadwell's security solution consists of our signature GRP grating panels and ArchitEX™ structural profiles. Constructed from premium resin systems, Treadwell's GRP fencing and screening solutions are ideal across a diverse range of industries. Designed with anti-climb features, along with security benefits like low conductivity and addressing safety concerns, these can be fitted with razor hoops and barbwire for added security, to give you added peace of mind.

Design Life

Minimum 50 years design life in case proven and also accelerated UV testing to ASTM G154-06.

Suitability

Our analysis shows that the capacities of the GRP members used for fence system are adequate to support shear and bending.

Deflection Note

The deflection at mid-height under serviceability wind condition is 90mm. The deflection limit recommended by Table C1 of AS/NZS 1170.0 for wall elements (Walls- General (face loaded)) is Height/150 at mid-height under serviceability wind conditions. This is equal to 25mm. The fence structure would deflect for a short time at the highest wind gust only.



Materials of Construction

GratEX® GRP Screening Mesh

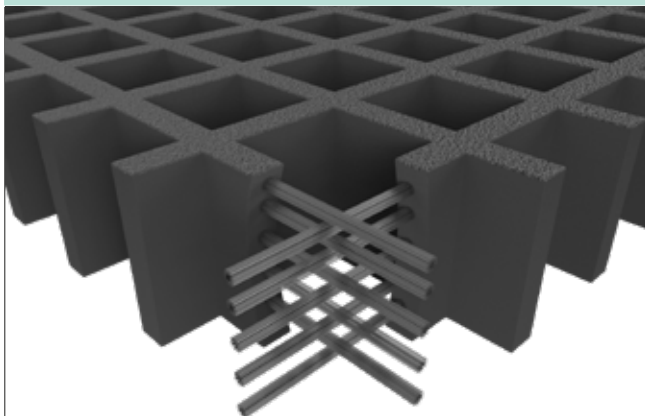

Screening is constructed using this method of manufacturing.

ArchitEX™ GRP Pultrusions

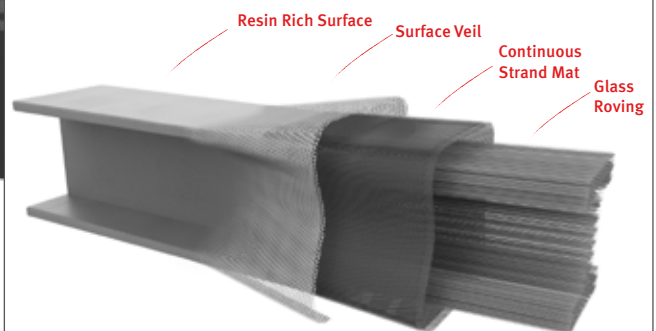

Palisade pickets post & rails are all constructed using a pultrusion process.

Case Study – Security Screening



PROJECT INFORMATION	
Project Category:	Substation Utilities Infrastructure
Scope of Work:	Supply Treadwell GRP Solution
Treadwell Products:	ArchitEX™ Structural Profiles GratEX® GRP Micro Mesh Grating Treadwell GRP Palisade Panel

In order to maximise space and prepare for high capacity metro trains, a multi-storey substation was custom designed to be installed in Melbourne’s CBD. This would be situated on a narrow strip of land, and had to be constructed within a tight timeframe. Prefabrication technology allowed the substation to be built off site at the same time as the foundation being installed; this saved time and eliminated the potential for weather delays. Consisting of a team of contractors, communication and action had to be precise.

Treadwell was engaged to supply the GRP products for the structure and security perimeter.



Treadwell's Solution:

- 1

Treadwell GRP fencing is suited to a wide range of rail applications, especially in areas where stray electrical currents are a concern.

- 2

Treadwell GRP Picket Fence is an anti-climb design, providing an added layer of security around the structure it protects. Easily installed on even and uneven ground.

- 3

GratEX® GRP Micro Mesh grating was selected as it accommodates wind loading concerns while providing a barrier against debris or foreign objects.

- 4

Being lightweight and easy to install, GRP is very manageable during construction.

- 5

Given the nature of GRP, any system utilising it is virtually maintenance free, keeping maintenance costs to a minimum.

Case Study – Security Fencing



PROJECT INFORMATION	
Project Category:	Utilities Infrastructure
Scope of Work:	Supply GRP fencing panels and razor hoops
Treadwell Products:	Treadwell GRP Palisade Fence System

Public Transport Victoria were in the process of building new substations to increase the power capacity on the network so that more trains could run with more reliability. These network upgrades are needed to allow High Capacity Metro Trains to run across Melbourne’s busy train network.

Treadwell was approached to provide a durable, non-corrosive fence solution that was electrically non-conductive as well as non-disruptive to the radio frequencies around the network.

In response, Treadwell provided, our line of GRP fencing from our structural profile range.



Treadwell's Solution:

- 1 Treadwell GRP fence systems are categorically chosen to suit the environments in which they will be installed in to counter corrosion.
- 2 Due to the nature of GRP, Treadwell GRP fence systems are electrically non-conductive which is ideal for this application.
- 3 Treadwell GRP fence systems are radio frequency transparent, allowing uninterrupted communications.
- 4 Being lightweight and easy to install, GRP is very manageable during construction.
- 5 Given the nature of GRP, any system utilising it is virtually maintenance free.

Case Study – Security Fencing



PROJECT INFORMATION	
Project Category:	Utilities Infrastructure
Scope of Work:	Design & supply GRP fencing
Treadwell Products:	Treadwell GRP Palisade fencing panels

Noble Park station is one of five stations that were completely rebuilt as part of the Caulfield to Dandenong Level Crossing Removal project. This included the replacement of nine crossings by using an elevated rail design. With more available public space, new amenities like a cycle route, parks, fitness areas and games courts, the urban design has improved traffic congestion, and has created a unified feel across neighbourhoods previously separated by a train line.

As part of the construction for the new Noble Park station, the power substation was relocated to the west of the station carpark. This new location was designed to create a new space for commuters as well as improve access to the street shops. Treadwell was engaged to provide the secure fencing for this substation.



Treadwell's Solution:

- 1

Treadwell GRP panels are constructed with non-conductivity properties, ensuring safety from potential stray electrical currents.

- 2

These GRP panels are termite- and rot-proof, and constructed with corrosion-resistant properties, making it an ideal solution for this outdoor application.

- 3

Treadwell GRP panels are an anti-climb design that provides an additional layer of security.

- 4

Treadwell GRP panels were customised to meet the aesthetic and practical requirements of the structure.

- 5

Given the nature of GRP, any system utilising it is virtually maintenance free, keeping maintenance costs to a minimum.

Our Partners





Strathalbyn, South Australia - Factory & Warehouse



Material Availability

We have established extensive stockholdings internationally, ready to be fabricated or shipped according to your project requirements. With offices and warehouses located throughout the APAC and UK regions, shipments can be quickly arranged.

Our in-house design and engineering teams have exceptional CAD capabilities. Our factory features top of the range automated CNC equipment allowing project requirements to be quickly fulfilled.

Strathalbyn, South Australia - Factory & Warehouse

United Kingdom

ABERDEEN (OFFICE)

- ▶ UNIT F8, ENTERPRISE CENTRE
ABERDEEN ENERGY PARK
AB238GX

New Zealand

NORTH ISLAND

▶ (OFFICE & WAREHOUSE)

36 RATANUI STREET AORANGI,
FEIDLING 4775

Australia

SOUTH AUSTRALIA

▶ ADELAIDE (HEAD OFFICE & WAREHOUSE)

58 DEEDS ROAD
NORTH PLYMPTON, SA 5037

▶ STRATHALBYN (FACTORY & WAREHOUSE)

22 DUNREATH ROAD
STRATHALBYN, SA 5255

VICTORIA

▶ GEELONG (SERVICED OFFICE)

33 MACKEY ST,
NORTH GEELONG, VIC 3215

NEW SOUTH WALES

▶ SYDNEY (SERVICED OFFICE)

SUITE 13D, 21 SYDNEY ROAD
MANLY, NSW 2095

▶ WAGGA (BRANCH OFFICE & WAREHOUSE)

13 CHESHIRE ST,
WAGGA WAGGA, NSW 2650

QUEENSLAND

▶ BRISBANE (SERVICED OFFICE)

SHOP 1, LEVEL 1, TOOWONG VILLAGE,
9 SHERWOOD RD, TOOWONG, QLD 4066

WESTERN AUSTRALIA

▶ PERTH (BRANCH OFFICE & WAREHOUSE)

3 RUNYON ROAD,
MIDVALE, WA 6056

TASMANIA

▶ BURNIE (DISTRIBUTION CENTRE)

28-30 BRICKPORT ROAD
COOEE, TAS 7320



TREADWELL™

COMPLETE “Fit & Forget” SOLUTIONS