

TREADWELL™

COMPLETE “Fit & Forget” SOLUTIONS

Sector Guide

MINING & MINERAL PROCESSING



ENGINEERING THE FUTURE IN COMPOSITES

www.treadwellgroup.global

Let Treadwell Help You Release the Power of Engineered Composites on Your Next Project

Corrosion Resistant



- Manufactured from premium isophthalic and vinyl ester resin systems.

Cost Savings

- Longer service life, less maintenance, and life cost savings as compared to other materials.
- Allows better and viable components into the associated framework.

High Strength

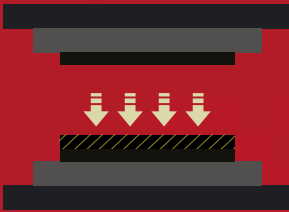

- Manufactured by automated pultrusion process.
- Utilises high glass-fibre content and results in unparalleled product consistency.
- Compression moulding and vacuum moulding processes are used.

Turnkey Solutions



- Pre-fabricated to eliminate field fabrication and make installation quick and easy.
- Solutions include all necessary accessories.

Customised System

- Our experienced technical team customises designs to meet project specific load requirements.

Durability



- Highly durable.
- Greater resistance to breaks and twists which ensure better longevity.
- Reduce the harmful effects of added tension on the surface and relieving the framework.



UV Protection

- Exterior coatings and stabilisers provide UV protection and ensure long service life.

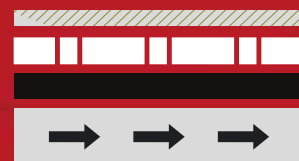

Low Profile

- Aesthetically pleasing flat covers.
- Eliminate confined-entry issues.
- Provide protection for equipment located on top of the cover instead of below.

Light Weight



- Strength-to-weight properties of GRP reduce loads on tank walls and floors.
- Ease cover removability and installation.
- Can be transported anywhere easily and installed seamlessly.

No Dissimilar Metals



- Eliminates issues surrounding dissimilar metals

Contents

04	What You Get When You Work with Treadwell
05	Bespoke & Specialised Projects - Our Process Explained
06	Why Choose Treadwell?
08	EX-Series® GRP Grating
10	Grating Clips
11	Case Study – Lithium Processing Plant
12	Case Study – Copper Concentrate Processing Plant
13	Case Study – Zinc Processing Plant
14	Case Study – Salt Wash Plant Screen Guards
15	Case Study – Metals Mining Facility
16	Case Study – Gold Mine Facility
18	RailEX® ROUND Tubular Handrail
19	RailEX® ROUND Overview
20	RailEX® ROUND Stanchion Kits & Handrail Parts
21	Case Study – Port Latta Iron Export Site
22	Case Study – Nickel Processing Plant
23	Case Study – Tailings Pump Station
24	EX-Series® Industrial Composite Solutions
25	Case Study – Chemical Manufacturing Plant
26	Case Study – GRP Pump Support & Access Structure
27	Case Study – Mineral Processing Plant Cooling Tower
28	Case Study – Salt / Bitterns Discharge Winch Tower & Bridge
30	EXduro™ Cable Ladders
31	Case Study – Zinc Refinery Plant
32	Case Study – Solar Salt Mine Processing Plant
34	EX-Series® LadderEX® GRP Ladders
35	LadderEX® Retract-A-Stiles
36	TREADSAFE™ Anti-Slip Safety Solutions
37	ArchitEX™ Composite Structural GRP
38	ArchitEX™ GRP Profiles
39	TreadSLAB® Panel Types Available
40	Case Study – Purlin Replacement
41	Our Partners



Quality Policy

Quality is at the forefront of Treadwell's working practices. With over 15 years of manufacturing to the highest quality standards, Treadwell prides ourselves on our reputation for implementing strict quality control measures, and strives to supply products that surpass customers expectations. The company works on a policy of 'continuous improvement'.



Environment Policy

Treadwell is conscious of the impact it has on the environment and its associated responsibilities. The company is committed to ensuring its operations satisfy legal obligations and other responsibilities. Treadwell remains committed to sustainability.

Disclaimer: The information contained in this Treadwell design guide herein supplied is as a service to our customers and is intended to be used only as a general guide. It is not a substitute for proven engineering practices and designs.

What You Get When You Work with Treadwell

Specialised Online Tools

Conveniently located online, our selection tool allows users to fill in selection criteria based on each product brand we carry and will recommend a product suitable to your needs. Our product information has been imprinted on the tool to provide ease of outline and inspiration to architects, engineers, designers and other users. Users can also find all our product files in PDF, DWG, STEP etc. files to download for each of our products.

Visit our website at <https://treadwellgroup.uk/treadspect> to try out these online specifier tools.



Friendly & Professional Design Support

Whether you're looking to upgrade or completely revamp your rail infrastructure assets, we can help support your design services across all stages of your project lifecycle. Our qualified and experienced engineering team have provided turnkey as well as purely design-based projects. With a knowledgeable team, we are able to provide solutions to fit your requirements.



Cutting Edge Technical Information

Treadwell has a LEAN manufacturing facility, approximately 4000m² under one roof. Our automated CNC equipment, including state-of-the-art 90,000 PSI waterjet cutting system and beam line ensures minimal material wastage, and as such, eliminates excessive costs. Our internal design engineering department is able to provide design expertise and sign off engineering in all states of Australia (RPEQ and NT certified), and an on-site Quality Assurance team to perform the necessary checks.



With a proven track record delivering large-scale projects across Oceania, we apply the same rigour and reliability to the UK market. Our long-standing partnerships with logistics providers, combined with hands-on fleet experience enable us to manage time-critical deliveries efficiently and consistently, meeting the expectations of UK clients.

Bespoke & Specialised Projects - Our Process Explained

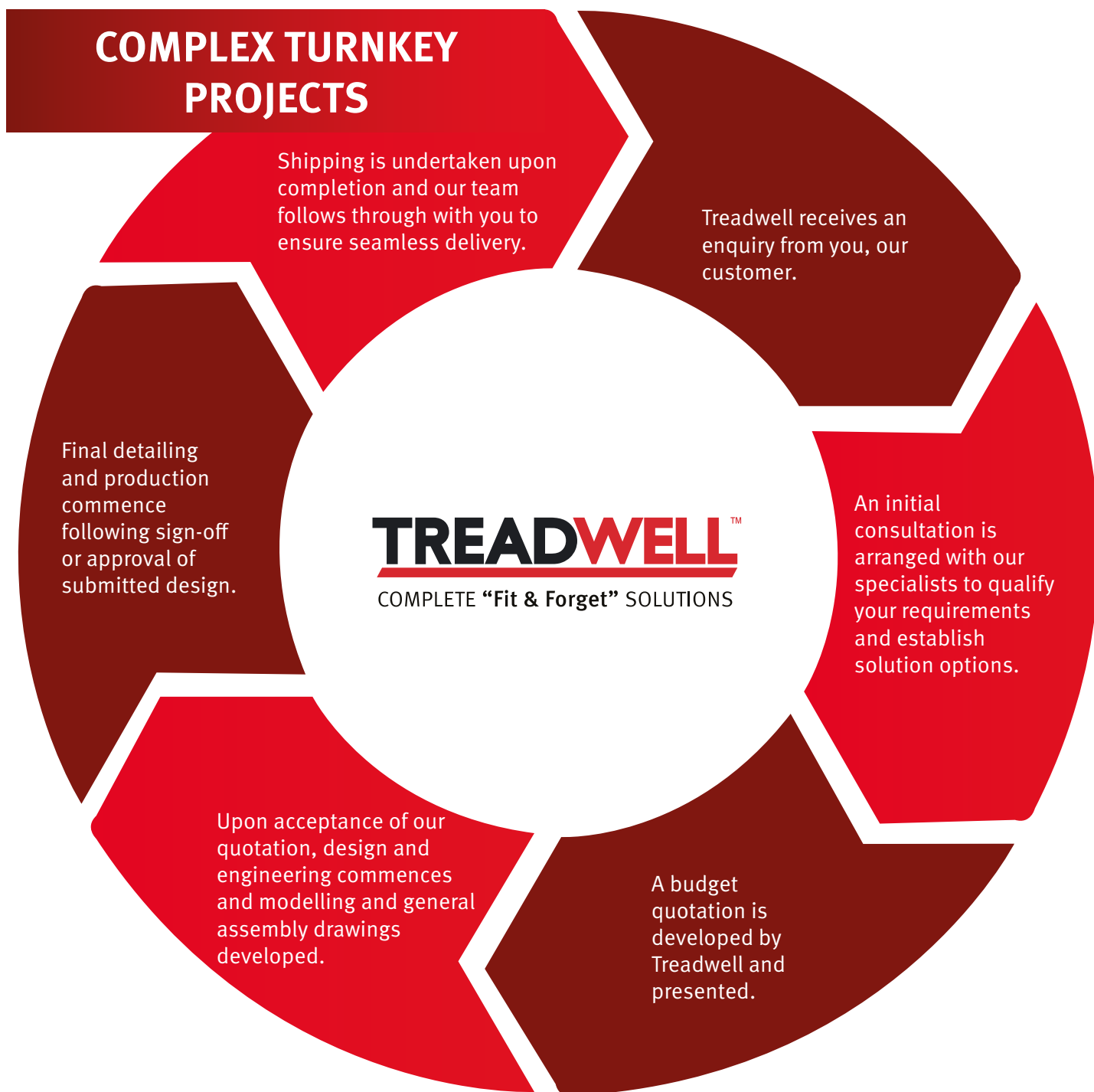

Why Choose Treadwell?

- 1 Our team of engineers are available to support your design requirements by providing technical expertise and specifications.
- 2 Our products are tested and meet relevant compliant codes where required.
- 3 We offer solutions based on practical calculations and data, providing the optimum products for your application.
- 4 We are an established name in Australia for providing durable and dependable GRP solutions.





Dampier, Western Australia - Dampier Salt Mine

What is EX-Series® GRP Grating?

Treadwell's GratEX® moulded GRP grating is a high strength, single piece construction mesh panel product. Treadwell offers both standard panel sizes as well as the option of custom panels made to order from your drawings, or alternatively, drawings provided by Treadwell's drafting department.

Cost effective GratEX® panels allow for effective on-site fabrication/trimming whilst ensuring that wastage is minimised. Load bearing bars in both directions allow for use without continuous side support and so contribute to cost effectiveness. GratEX® offers all the benefits available with grating made from other materials plus a host of superior benefits unequalled by steel or other metal alternatives.



GratEX® Surface Options

Anti-Slip Surface (Standard). This surface is most commonly used in industrial applications. It is very hard wearing and boasts an extremely effective coefficient of friction (NATA laboratory test report available). Unlike serrated steel, the anti-slip surface does not impact load carrying capacity.

Concave Surface. This is preferred for environments where by-products are commonly caught by serrations, and is hence very often utilised by the food industry. This surface option can also be used for guarding options to allow safe handling/ contact.

Plain Surface. This is a stock option that is widely utilised for guarding and architectural features in a variety of applications. Whilst the aesthetics of the product are improved, the anti-slip properties are not as profound as the other options available.



Treadwell EX-Series® GRP Grating

Treadwell EX-Series® Glass Reinforced Plastic (GRP) grating products are recommended for areas where physical properties are paramount to design and longevity. Treadwell offers an extensive range of GRP grating products, two of which are highly utilised in the rail industry. There are key differences to take note of. The information below outlines the key differences and the ideal scenarios in which the different types of grating are to be utilised.

GratEX® Moulded GRP Grating

The perfect solution for areas where excessive amounts of penetrations (i.e. for piping) call for traditional uni-directional spanning products. This greatly increases the costs when using traditional materials, like steel. GRP grating maintains strength and integrity even with multiple penetration cut outs, while keeping costs low.

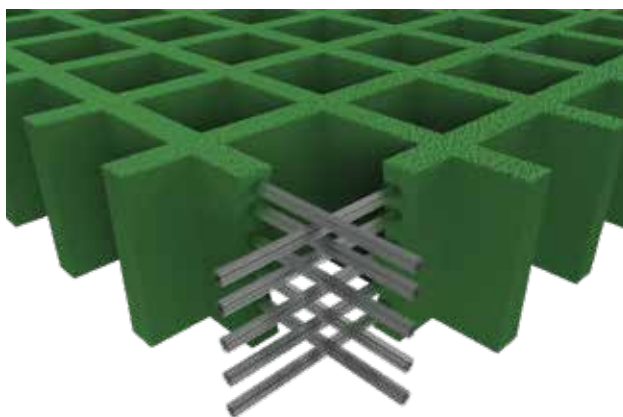

GridEX® Pultruded GRP Grating

The ultimate choice for areas where extremely high loadings, or larger spans present a challenge. Such applications include wide walkways, or where equipment needs to be installed on top of grating.

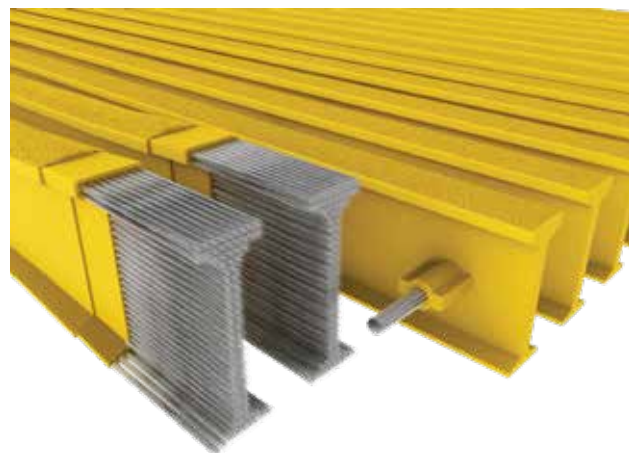

Please consult our EX-Series® Grating Product Guide for more information.









GratEX® Clip - Tops

STANDARD M	MINI MESH M	MINI MESH M (SLOTTED)	C	L
Hole Diameter: 8mm Material type: 316 st/st Threaded hole: N/A	Hole Diameter: 6mm (8mm for GTX-502525M1) Material type: 316 st/st Threaded hole: N/A	Hole Diameter: 6mm Material type: 316 st/st Threaded hole: N/A	Hole Diameter: 6mm Material type: 316 st/st Threaded hole: Yes	Hole Diameter: 6.5mm Material type: 316 st/st Threaded hole: N/A
				

D	E	W	S	O
Hole Diameter: 8.5mm, 7mm Material type: 316 st/st Threaded hole: N/A	Hole Diameter: 8mm Material type: 316 st/st Threaded hole: N/A	Hole Diameter: 8mm Material type: 316 st/st Threaded hole: N/A	Hole Diameter: 8mm Material type: 316 st/st Threaded hole: N/A	Hole Diameter: 8mm Material type: 316 st/st Threaded hole: N/A
				

Clamp Underside

J - UNIVERSAL	J - MINI-MESH	H
Hole Diameter: N/A Material type: 316 st/st Threaded hole: N/A	Hole Diameter: N/A Material type: 316 st/st Threaded hole: N/A	Hole Diameter: 8mm Material type: st/st Threaded hole: Yes
		

G	U	V	T
Hole Diameter: 6mm, 8mm Material type: st/st Threaded hole: Yes	Hole Diameter: 8mm Material type: 316 st/st Threaded hole: Yes	Hole Diameter: 8mm Material type: 316 st/st Threaded hole: N/A	Hole Diameter: N/A Material type: 316 st/st Threaded hole: N/A
			

Case Study – Lithium Processing Plant

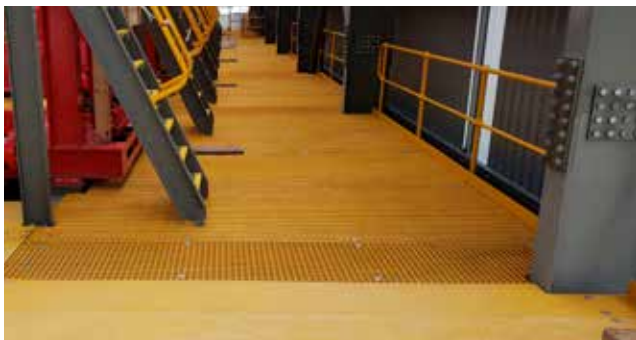

PROJECT INFORMATION	
Project Category:	Mineral Processing Plant
Scope of Work:	Supply GRP grating
Treadwell Products:	EX-Series® GratEX® GRP Square Mesh Grating EX-Series® GridEX® GRP I-Type Grating EX-Series® GridEX® GRP Solid Top Grating

Based in Western Australia, this lithium hydroxide processing plant is the first to produce battery grade lithium in commercial quantities for the electric vehicle industry. A top-tier production plant in terms of scale and technology, the construction of this plant required various types of grating installed at different parts of the structure.

Treadwell was engaged to supply the required grating.



Treadwell's Solution:

- 1

GratEX® GRP Square Mesh grating is easily customised, hardwearing and features excellent co-efficient of friction.

- 2

GridEX® GRP I-Type grating is manufactured and designed with the structural integrity associated with metal grating systems, without the associated corrosion problems. This pultruded grating includes high resistance to fatigue.

- 3

GridEX® GRP Solid Top grating includes all the features of the I-Type grating, with a solid top deck. This was installed in areas where the apertures in the grating were not required.

- 4

Treadwell GRP grating addressed corrosion concerns.

- 5

GRP is easily installed without the need for heavy machinery, and any variance on tasks is managed with hand tools, eliminating the need for any hot works permit.

Case Study – Copper Concentrate Processing Plant



PROJECT INFORMATION	
Project Category:	Mineral Processing Plant
Scope of Work:	Supply GRP products
Treadwell Products:	EX-Series® GratEX® GRP Mini Mesh Grating EX-Series® GratEX® GRP Square Mesh Grating & Stair Treads

South Australia – Located approximately 160km from Port Augusta, this mine is one of the biggest underdeveloped copper projects in Australia. After delays caused by the COVID-19 pandemic, expansions plans were finally approved in 2021. This will increase production to 12 million tonnes per annum by 2023.

Treadwell was engaged to supply the grating and stair treads for the expansion plans.



Treadwell's Solution:

- 1

GratEX® GRP Stair Treads are constructed with a solid nose leading edge. This increases the rigor and sturdiness of the entire leading edge, ensuring dependable performance in high traffic situations.

- 2

GratEX® GRP Square Mesh grating allows maximum debris to fall through, eliminating the risk of matter build up, with a self-maintaining anti-slip surface for maximum user safety.

- 3

GratEX® GRP Mini Mesh grating has apertures to allow water to fall through, eliminating the risk of stagnant water and creating a self-maintaining anti-slip surface.

- 4

Constructed from premium resin systems, Treadwell's GRP grating is corrosion resistant, with fire retardant properties, as well as UV inhibitors, making it ideal for this outdoor and corrosive environment.

Case Study – Zinc Processing Plant



PROJECT INFORMATION	
Project Category:	Mineral Processing Plant
Scope of Work:	Supply GRP grating
Treadwell Products:	EX-Series® GratEX® GRP Square Mesh Grating

Northern Territory – Located on one of the world’s largest deposits of zinc and lead, mining site includes an open cut mine and processing facilities. In these corrosive manufacturing conditions, a high performance, long lasting and durable product was required for the decking for the facilities.

Treadwell was engaged to supply the GRP grating to meet these requirements.



Treadwell's Solution:

- 1

GratEX® GRP Square Mesh grating is extremely versatile, with a high strength to weight ratio, presenting as the ideal high-performance alternative to steel.

- 2

GratEX® GRP grating is corrosion resistant, and minimises mechanical damage during removal.

- 3

Easily clipped into place with hand tools, GratEX® GRP grating is also easily removed when needed for access to repairs and maintenance requirements.

Case Study – Salt Wash Plant Screen Guards



PROJECT INFORMATION	
Project Category:	Mineral Processing Plant
Scope of Work:	Supply GRP grating
Treadwell Products:	EX-Series® GratEX® GRP Square Mesh Grating & Stair Treads

Shark Bay, Western Australia – Our client was contracted to review a salt mining company’s pilot plant, with a view to upgrade their existing salt wash plant. The new plant would provide increased throughput, similar recoveries, a more reliable plant and increased life expectancy.

Treadwell was engaged to provide the GRP grating for the decking and screen guards.



Treadwell's Solution:

- 1

EX-Series® GratEX® GRP stair treads are moulded with the solid leading edge as a joint single stage component. This increases the rigor and sturdiness of the entire leading edge, ensuring dependable performance in high traffic situations.

- 2

GratEX® GRP Square Mesh Grating panels are designed to be high strength and made as a single piece construction mesh panel. This helps with easy installation.

- 3

Treadwell's GRP is corrosion resistant, with RF transparent properties, making it ideal for this application.

Case Study – Metals Mining Facility



PROJECT INFORMATION	
Project Category:	Mineral Producing Plant
Scope of Work:	Supply GRP grating
Treadwell Products:	EX-Series® GratEX® GRP Square Mesh Grating

Roxby Downs, South Australia – This mine is one of the world’s most significant deposits of copper, gold and uranium. Made up of underground and surface operations, this mine site has a fully integrated processing facility from ore to metal.

As part of maintenance, the decking in some areas the facility needed to be replace. Treadwell was engaged to supply the GRP grating.



Treadwell's Solution:

- 1

Treadwell’s team of engineers are skilled in ensuring grating deflection meets the relevant compliance codes and industry standards.

- 2

EX-Series® GratEX® GRP Square Mesh grating allows for maximum flow through of debris, while remaining anti-slip for user safety.

- 3

With a ready stock of GratEX® grating panels, repairs and replacements, if any, are easily managed.

Case Study – Gold Mine Facility



PROJECT INFORMATION	
Project Category:	Mineral Processing Plant
Scope of Work:	Supply GRP grating
Treadwell Products:	EX-Series® GratEX® GRP Solid Top Grating

Kalgoorlie, Western Australia – One of Australia’s largest open pit gold mines, this mining operation is a world class asset located adjacent to the City of Kalgoorlie-Boulder. Operations include an underground mine and processing plants.

Treadwell was engaged to supply GRP solid top grating as part of their structural works.

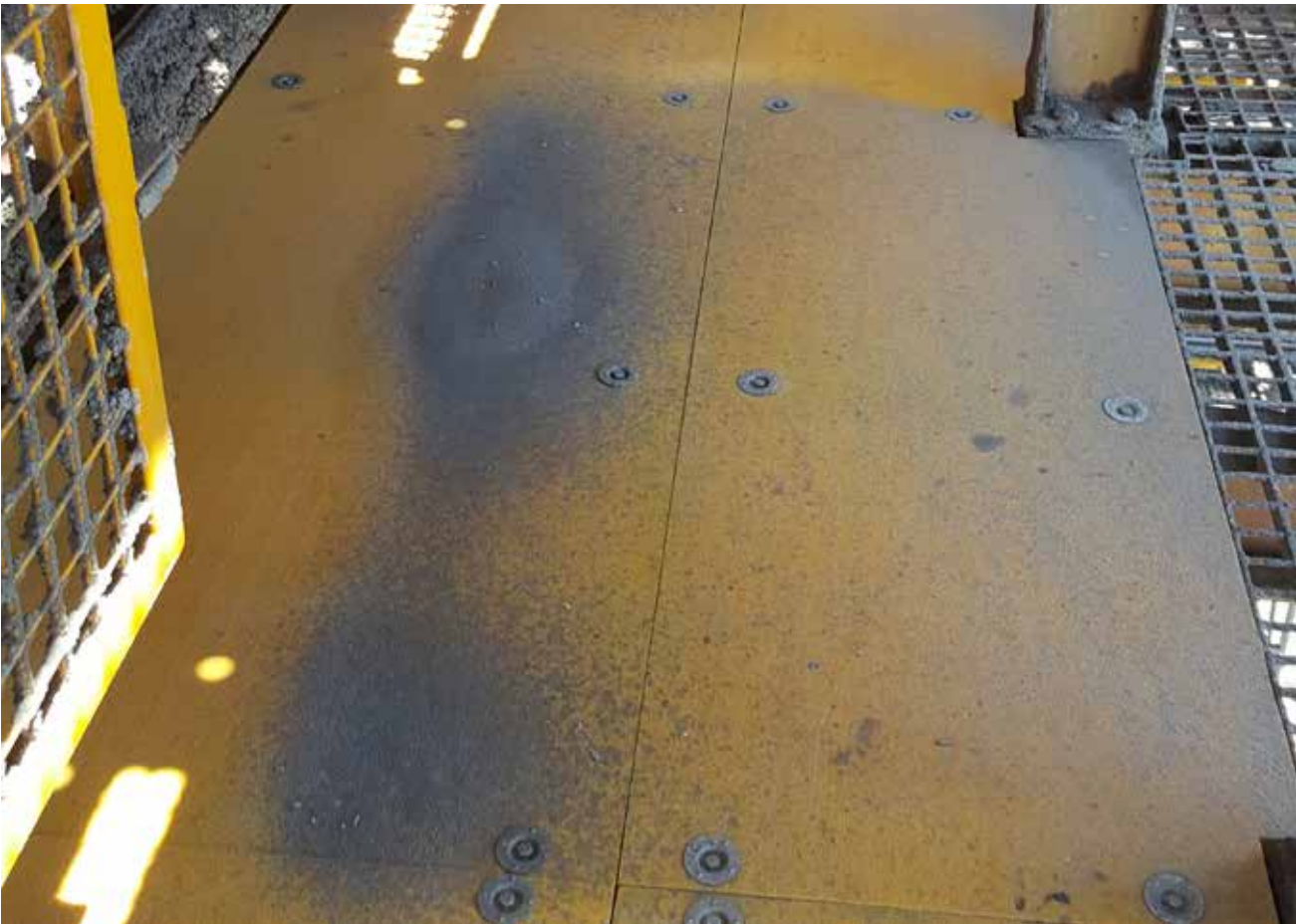

Treadwell's Solution:

- 1** EX-Series® GratEX® GRP solid surface grating is based on the standard square mesh with a covered solid top, this is ideal in areas where openings in the grating are not required, or create concerns for users.
- 2** Treadwell's GRP products meet the relevant Australian standards and compliance codes, ensuring dependability, even in harsh conditions.



Western Australia - Nickel Processing Plant

What is RailEX® ROUND Tubular Handrail?

Treadwell's RailEX® ROUND Tubular Handrail is an industrial rated composite handrail system which combines strength, durability and versatility meaning the system is ideal for use in numerous applications in a vast range of industries. Treadwell can supply RailEX® as either components or as fabricated handrail panels ready for installation.

Smart Transposable Designs

Unlike traditionally welded alternatives, Treadwell GRP handrail system dispenses the need for drafting, engineering and onsite fabrication while minimising installation costs. Treadwell's safety handrail systems can be adapted or extended with additional components, or cut to size onsite. Pre-engineered kits are supplied as a series of components with simple assembly instructions. With our clients in mind, Treadwell aims to minimise the cost of maintenance and repairs, and damaged components easily with readily available parts and stock.

Simple Zero Weld Assembly

As an added benefit, fibreglass handrail kits are assembled using a simple, zero weld construction method; reducing the chances for corrosion activation. Treadwell's RailEX® designs and fittings effectively eliminate the need for specialist trades, hot works permits, fire spotters and welding protection to finished surfaces. Our selection of GRP increases safety conditions for installers by eliminating toxic fumes, welding in wet areas and fire risk hazards.

Developed by Treadwell with the input of designers, and plan operators, this system offers you all benefits of traditional guardrail systems without the inherent problems - corrosion, welding and hot works permits for onsite modifications. This unique system is a first to be tested and conform with Australian Standards AS 1657. RailEX® is the **'Fit & Forget'** handrail system.



This product conforms to AS1657



RailEX® Features and Benefits vs. Traditional Alternatives

	RailEX®	Stainless Steel	Galvanised Steel	Aluminium	Timber
Chemical Resistance	•••••	•••••	•	•••	•••••
Strength	•••••	•••••	•••••	•••••	••
Lightweight	•••••	•	•	•••••	••
Electrical Resistance	•••••	•	•	•••••	•••••

Materials of Construction

RailEX® GRP handrail is constructed from fibreglass rovings combined with a blend of thermosetting resin systems. All of the resins used in the production of EX-Series® products contain UV inhibitors and fire retardant additives.



RailEX® ROUND Overview

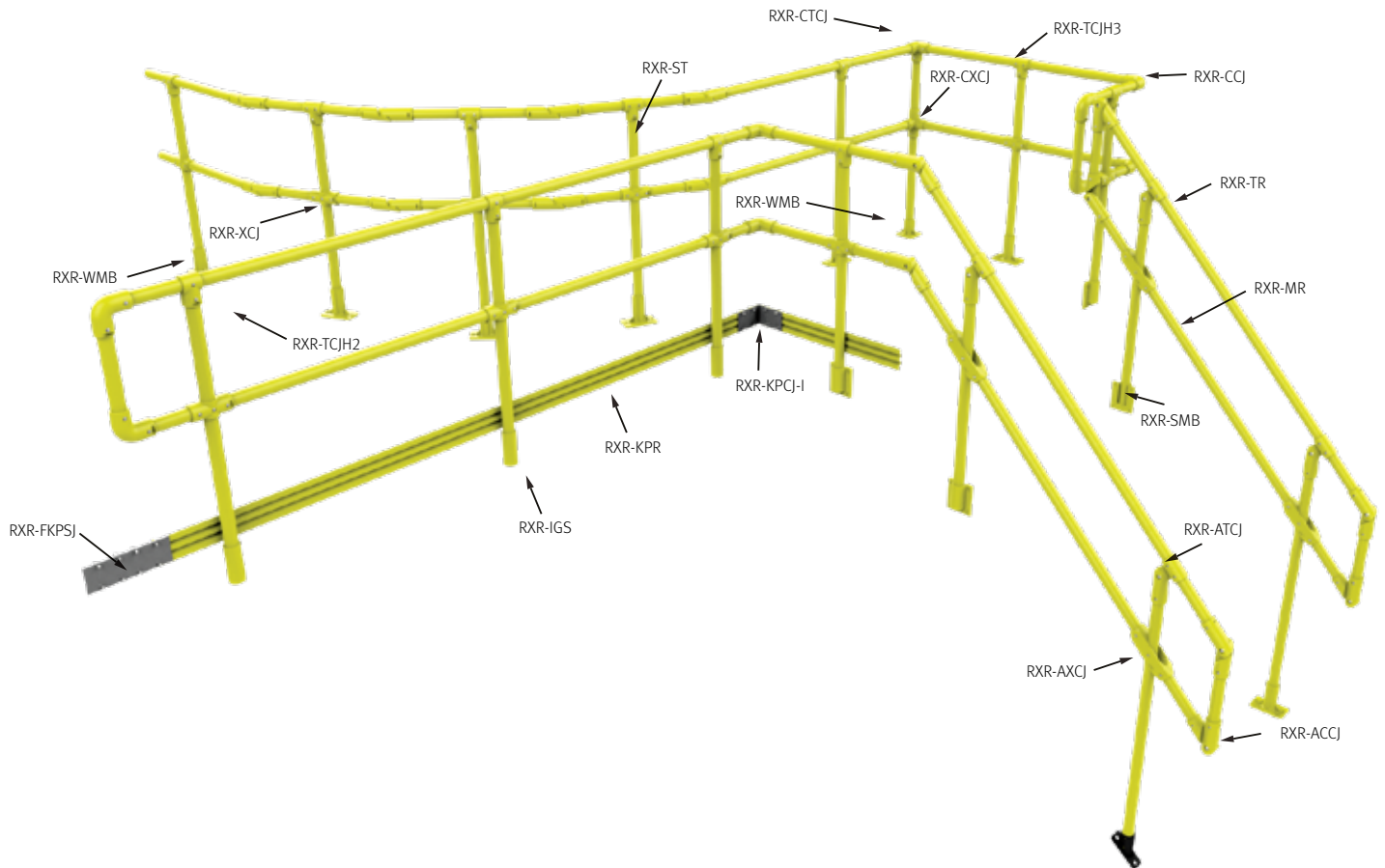

Please consult our RailEX® Handrail Installation and Product Guides for more information.



RailEX® ROUND Stanchion Kits & Handrail Parts

Treadwell has created options of RailEX® handrail stanchion kits. This ensures that all the required parts are included, making for easy planning and installation. Please note that the list below is just a selection of our most popular handrail assemblies. For a more comprehensive selection, please consult our RailEX® Product Guide .

RXR-SN-VY-K	RXR-SS-VY-K	RXR-AA-VY-K	RXR-AS-VY-K
<p>RailEX® ROUND Stanchion Sales Kit, Standard Stanchion with Narrow Mounting Bracket, V-Series® Safety Yellow, including Stainless Steel Fasteners.</p> <p>NOTE: Assembly excludes fasteners to connect to structure.</p>	<p>RailEX® ROUND Stanchion Sales Kit, Standard Stanchion with Side Mounting Bracket, V-Series® Safety Yellow, including Stainless Steel Fasteners.</p> <p>NOTE: Assembly excludes fasteners to connect to structure.</p>	<p>RailEX® ROUND Stanchion Sales Kit, Adjustable Stanchion with Angled Round Top Mount Bracket, V-Series® Safety Yellow, including Stainless Steel Fasteners.</p> <p>NOTE: Assembly excludes fasteners to connect to structure.</p>	<p>RailEX® ROUND Stanchion Sales Kit, Adjustable Stanchion with Side Mounting Bracket, V-Series® Safety Yellow, including Stainless Steel Fasteners.</p> <p>NOTE: Assembly excludes fasteners to connect to structure.</p>
<p>RXR-CC Standard ROUND Fibreglass 90° Corner Connection Joint</p>	<p>RXR-XCJ Standard ROUND Fibreglass Cross Connection Joint</p>	<p>RXR-TCJH2 Standard ROUND Vertical Fibreglass Connection Joint</p>	<p>RXR-TCJH3 Standard ROUND Horizontal Fibreglass Tee Connection Joint (three holes)</p>
<p>RXR-TRJ Standard ROUND Fibreglass Top Rail Joiner</p>	<p>RXR-ACCJ Adjustable ROUND Fibreglass Corner Joint</p>	<p>RXR-AXCJ Adjustable ROUND Fibreglass Cross Connection Joint</p>	<p>RXR-ATCJ Adjustable ROUND Fibreglass Tee Connection Joint</p>
<p>Standard Stainless Steel Driver Kit M6 Type with Trilobular Head</p>	<p>RXR-SMB Standard ROUND Fibreglass Side Mounting Bracket</p>	<p>RXR-NMB Standard ROUND Fibreglass Narrow Mounting Bracket</p>	<p>Standard Stainless Steel Fastener Kit M6 with Trilobular Head (stock item)</p>
<p>Standard Stainless Steel Fastener Kit M10 (stock item)</p>	<p>Standard Stainless Steel Fastener Kit M6 with Trilobular Head (stock item)</p>	<p>Standard Stainless Steel Fastener Kit M6 with Trilobular Head (stock item)</p>	<p>Standard Stainless Steel Fastener Kit M6 with Trilobular Head (stock item)</p>

Case Study – Port Latta Iron Export Site



PROJECT INFORMATION	
Project Category:	Iron Ore Production Facility
Scope of Work:	Supply GRP products
Treadwell Products:	EX-Series® GratEX® GRP Grating EX-Series® RailEX® Round Handrail

The iron ore production facility in Port Latta is one of Australia’s largest and has been serving global markets for many decades. Set to increase its annual production of iron pellets in the coming years, this production plant is not slowing down.

To ensure the safety of their workers, Treadwell was engaged to provide safe access in the production facility. Keeping in mind the projected high levels of productivity, it was specified that the products used would be quick to install and would not require regular downtime for maintenance.



Treadwell's Solution:

- 1

GratEX® GRP Grating is constructed with an anti-slip surface, providing superior slip resistance.

- 2

RailEX® Round handrails provide dependable and safe support.

- 3

GRP is simply fabricated and modified on site. This means there is no need for any hot works permit.

- 4

Being lightweight and easy to install, GRP is very manageable during construction.

- 5

Given the nature of GRP, any system utilizing it is virtually maintenance free, keeping maintenance costs to a minimum.

Case Study – Nickel Processing Plant



PROJECT INFORMATION	
Project Category:	Mineral Processing Plant
Scope of Work:	Supply GRP handrail
Treadwell Products:	EX-Series [®] RailEX [®] ROUND GRP Handrail

Based in Western Australia, this is Australia’s leading nickel producer with two of the highest-grade nickel mines in the world. As a publicly listed company, they are focused on safely, sustainably and ethically delivering products to advance the global transition to decarbonization. As part of upgrading works at this processing plant, the existing handrails needed to be replaced.

Treadwell was engaged to supply the GRP handrails, to be retrofitted to the existing structure.



Treadwell's Solution:

- 1** EX-Series[®] RailEX[®] GRP handrails are assembled using a zero-weld method of putting the system together, which greatly minimises the chances of corrosion.
- 2** RailEX[®] GRP handrails are lightweight and can be installed without the need for heavy tools, making it ideal for this retrofit application.
- 3** RailEX[®] GRP handrails are constructed from premium resin systems, with corrosion resistant properties, as well as being rot- and termite-proof.

Case Study – Tailings Pump Station



PROJECT INFORMATION	
Project Category:	Mineral Processing Plant
Scope of Work:	Supply GRP handrail
Treadwell Products:	EX-Series® RailEX® SQUARE GRP Handrail

South Australia – This ore processing plant had an expansion plan in place to increase their production capabilities. Our client was contracted to construct a new storage facility including the related fabrication and installation of pipes, instrumentation, valves and pumps.

Treadwell was engaged to supply the GRP handrails for this expansion.



Treadwell's Solution:

- 1

EX-Series® RailEX® GRP handrails are constructed with UV Inhibitors and fire retardant properties.

- 2

RailEX® GRP handrails is the choice alternative to metallic handrails and offers radio frequency transparency, while being non-conductive in nature.

- 3

RailEX® GRP handrails have low thermal conductivity making it ideal for this outdoor application.

What is EX-Series® Industrial Composite Solutions?

A designed composite structural and access solution featuring a combination of our GRP products.

These access structures are easily installed in elevated, remote, indoor or outdoor locations, and possess corrosion resistant and low electrical conductivity properties.



FIXED STAIRCASES

An GRP solution featuring a combination of ArchitEX™ structural profiles, EX-Series® grating and stair treads, and RailEX® handrails. Built to withstand corrosive indoor and outdoor environments.

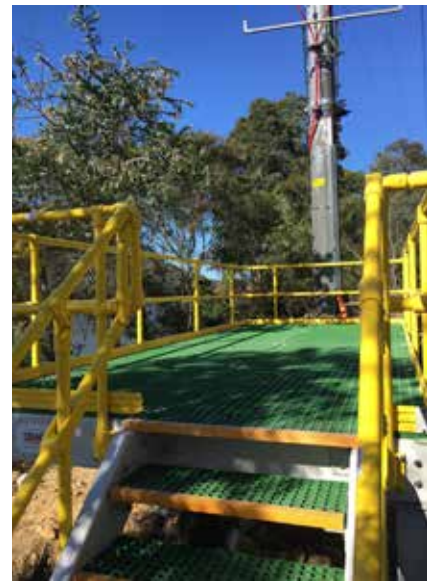

FIXED ACCESS PLATFORMS

These can be customised to the span required for its purpose. Being naturally non-conductive, GRP is a cost-effective and long-lasting solution for electrically sensitive environments.



FIXED STEPOVERS

All GratEX® and MoultrEX® premium and standard Stair Tread options are moulded with the solid leading-edge nosing as joint single stage component. This increases the rigor and sturdiness of the entire leading edge ensuring dependable performance in high traffic situations. All the treads with abrasive leading-edge nosings are manufactured to conform to AS 1657 – 2018.



RAIL PLATFORMS

Treadwell's TreadSLAB® GRP panels are constructed with an anti-slip surface and corrosion resistant properties. This maintains optimal user safety. Panels can also be customised according to load requirements.

Case Study – Chemical Manufacturing Plant



PROJECT INFORMATION	
Project Category:	Chemical Manufacturing Plant
Scope of Work:	Supply EX-Series® GRP Solution
Treadwell Products:	EX-Series® GratEX® GRP Square Mesh Grating EX-Series® RailEX® ROUND Handrails ArchitEX™ secondary framing & joists

A diversified chemical manufacturer, this proudly Australian owned company has multiple plants in Australia and Malaysia. Established in the early 1970s, they have come a long way and have expanded their portfolio over the years. In addition to chemical manufacturing, their capabilities include related bulk chemical and fuels storage and handling, as well as terminal infrastructure management. One of their major business commitments is the focus on operational safety.

As part of the extension of their plant in Brisbane, Treadwell was engaged to supply the GRP grating and handrails.



Treadwell's Solution:

- 1

Treadwell's EX-Series® GratEX® GRP grating and RailEX® ROUND handrails ensure durability with built-in corrosion resistant properties.

- 2

Treadwell's ArchitEX™ secondary framing and joists are non-conductive and non-corrosive, making it ideal for this application.

- 3

With a ready stock of GratEX® grating panels and RailEX® parts, repairs and replacements, if needed, are easily managed.

- 4

GratEX® stair treads moulded with a solid leading-edge stair nosing were used. This increases the rigor and sturdiness of the entire leading edge, ensuring dependable performance in high traffic situations.

- 5

GRP is simply fabricated and modified on site. This means there is no need for any hot works permit.

- 6

Being lightweight and easy to install, GRP is very manageable during construction.

Case Study – GRP Pump Support & Access Structure



PROJECT INFORMATION	
Project Category:	Mining Infrastructure
Scope of Work:	Supply EX-Series® GRP Solution
Treadwell Products:	EX-Series® GratEX® GRP Square Mesh Grating EX-Series® RailEX® ROUND GRP Handrail ArchitEX™ GRP Structural Profiles

Kalgoorlie, Western Australia – This fully Australian owned gold mine facility is a world class asset located adjacent to the City of Kalgoorlie-Boulder, approximately 600km east of Perth. The 1893 gold rush resulted in the discovery of the Golden Mile, one of the richest gold deposits in the world, producing more than 60 million ounces of gold.

As part of upgrades, pump support and access structures were needed for a Warman pump. Treadwell was engaged to supply the GRP products for these upgrades.

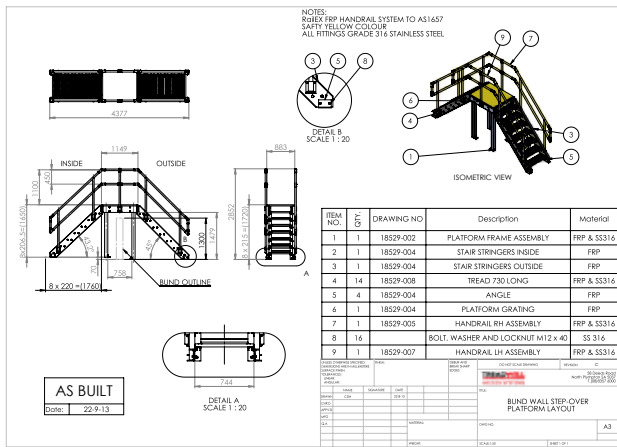

Treadwell's Solution:

- 1 The resin systems used in Treadwell's GRP products are customised to suit its application. This includes corrosion resistant properties, with a fire retardant formula.
- 2 The aperture of the GratEX® GRP Square Mesh allows maximum fall through of debris, minimising the impact of stagnant debris.
- 3 Treadwell's GRP products are RF transparent and has low thermal and electrical conductivity, ensuring user safety.
- 4 GRP is simply fabricated and modified on site. This means there is no need for any hot works permit.
- 5 Being lightweight and easy to install, GRP is very manageable during construction.

Case Study – Mineral Processing Plant Cooling Tower



PROJECT INFORMATION	
Project Category:	Mineral Processing Plant
Scope of Work:	Supply EX-Series® GRP Solution
Treadwell Products:	EX-Series® GratEX® GRP Square Mesh Grating & Stair Treads EX-Series® RailEX® ROUND GRP Handrail ArchitEX™ GRP Structural Profiles

Based in South Australia, this is a fully integrated processing facility of minerals from ore to metal. As part of operations, this mineral processing plant needed a new cooling tower installed, and their existing cooling tower to be decommissioned and demolished.

Treadwell was engaged to supply the GRP products.



Treadwell's Solution:

- 1

GratEX® GRP Stair Treads are constructed with a solid nose leading edge. This increase the rigor and sturdiness of the entire leading edge, ensuring dependable performance in high traffic situations.

- 2

GratEX® GRP Square Mesh grating allows maximum debris to fall through, eliminating the risk of matter build up, with a self-maintaining anti-slip surface for maximum user safety.

- 3

ArchitEX™ GRP Structural Profiles are manufactured from a pultrusion process, specifically designed to endure all sorts of environmental inconsistencies.

- 4

Treadwell's GRP products are constructed from premium resin systems with corrosion resistant and fire retardant properties, as well as UV inhibitors, making it ideal for this application.

Case Study – Salt / Bitterns Discharge Winch Tower & Bridge



PROJECT INFORMATION	
Project Category:	ArchitEX™ structure
Scope of Work:	Design & supply EX-Series® GRP Solution
Treadwell Products:	ArchitEX™ GRP Structural Profiles EX-Series® GratEX® GRP Square Mesh Grating EX-Seires® RailEX® ROUND GRP Handrail

Particular attention had to be paid to the extremely corrosive environment the winch tower would sit in – this meant that the majority of conventional materials would be eliminated for selection.

Our client’s engineering team worked in close conjunction with our GRP design and development personnel throughout the whole project to build a lightweight, corrosion resistant and cyclone rated structure that was capable of supporting a heavy duty winch with a S.W.L. of 5 tonnes. The resulting construction consisted of all members made of Fibreglass, joined together using 316 grade stainless steel bracketry

As it was necessary to have personnel access on the winch, a bridge section was developed to span the 7 metres between a bank of earth and the tower. GratEX® was used to make certain that all personnel accessing the tower would enjoy safe and secure footing in conjunction with RailEX®, Treadwell’s GRP hand railing system.

The structure was fully trial assembled and then partly dismantled and packed into modules to be delivered on time in full.

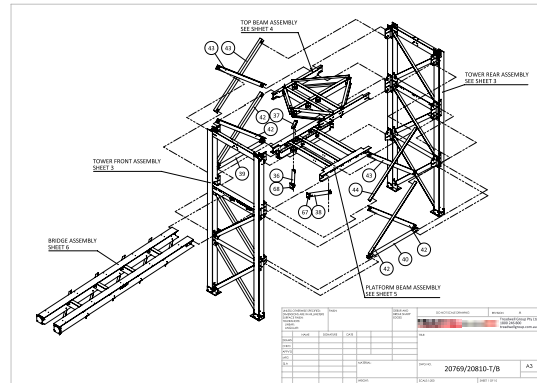

Treadwell's Solution:

- 1 ArchitEX™ GRP columns, beams and other supporting profiles were specified as the skeleton of the structure. GratEX® GRP grating and RailEX® GRP handrail were supplied to provide safe access. Specially formulated resin was categorically determined to withstand the corrosion.
- 2 The ArchitEX™ profiles were tested to be cyclone rated.
- 3 Being lightweight and easy to install, GRP is very manageable during construction.
- 4 Given the nature of GRP, any system utilising it is virtually maintenance free.
- 5 GRP is high in strength. Based on the resin formula and engineered design, the structure was capable to support the heavy duty winch.



R
UT
SS

DANGER
NO CUTTING
NO WELDING

DANGER
FLAMMABLE
MATERIALS

DANGER
NO CUTTING
NO WELDING
WITHOUT PERMIT



ABUSE
POWDER



South Australia - Mineral Processing Plant

EXduro™ Cable Ladders

For environments where corrosive elements play a crucial part in a material, Treadwell has developed its GRP cable ladders as a strong support solution as the alternative to metal cable ladders. Being lightweight, it allows for easier installation or onsite fabrication as well as giving the cable ladder a high strength to weight ratio.





EXduro™ fibreglass cable ladders has several other benefits that may be useful. It is both a UV resistant and fire retardant system. Transparent to RF frequencies and electrically non-conductive are other positives it can bring to any design.

EXduro™ fibreglass cable ladders are also a cost competitive, performance proven alternative to metal systems for that corrosive/chemical environment to run your electrical cable and instrumentation pipe work. With minimal to no ongoing maintenance, Treadwell's system is supplied with both GRP and stainless steel fasteners to suit your application.

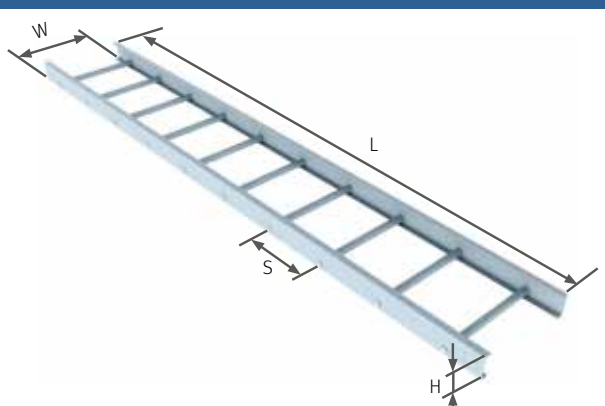
F-EXD-CL-C(H)(W)-(R)(S)-(RS)(C)-(L)						
Side Rail Height (H)	Width (W)	Rung Type (RT)	Rung Spacing (S)	Resin (RS)	Colour (C)	Length (L)
50mm (050)	150mm (150)	Standard Rung (S)	150mm (150)	Standard Polyester (SI)	Light Grey (LG)	3m (1) N
75mm (075)	300mm (300)	Marine Rung (M)	250mm (250)	Standard Vinylester (SV)	Custom Colour (CC)	6m (2) C
100mm (100)	450mm (450)		300mm (300)	Conductive Polyester (CI)		
150mm (150)	600mm (600)		450mm (450)	Conductive Vinylester (CV)		
200mm (200)	750mm(750)			Halogen free Polyester (HI)		
	900mm (900)			Halogen free Vinylester (HV)		
				Halogen free Low Smoke Plus (HF)		

EXduro™ Cable Ladder



Straight splice plate	90 Vertical splice plate
	
Adjustable vertical splice plate	Adjustable Horizontal splice plate
	

Cable Ladder Splice Plates

Our splice plates are available in both horizontal and vertical degree sections. We also offer the accompanying accessories separately. We construct both flat and peaked covers. These plates are non-conductive and do not react on electric and magnetic fields.

Case Study – Zinc Refinery Plant



PROJECT INFORMATION	
Project Category:	Mineral Processing Plant Cable Management
Scope of Work:	Supply GRP cable ladders
Treadwell Products:	EXduro™ GRP Cable Ladder

Townsville, Queensland – This zinc refinery produces a special grade of zinc metals. Secondary products produced include Sulphuric acid, low grade zinc concentrate and copper cake. These products are then sold to the international and domestic markets.

As part of upgrading works to the refinery, this processing plant required an organised method of running their electrical cables. Treadwell was engaged to supply our EXduro™ GRP cable ladders for this purpose.



Treadwell's Solution:

- 1

EXduro™ GRP Cable Ladders, Trays and Instrument Stands do not rust even in constant exposure to various oxidising conditions.

- 2

EXduro™ GRP products can be customised to fit the application, and various resins systems can be utilised to provide optimum performance.

- 3

EXduro™ GRP products are lightweight, which reduces costs for transport, and can be easily installed without the need for heavy machinery, further minimising total costs.

- 4

Given the nature of GRP, any system utilising it is virtually maintenance free, keeping maintenance costs to a minimum.

Case Study – Solar Salt Processing Plant



PROJECT INFORMATION	
Project Category:	Mineral Processing Plant
Scope of Work:	Supply GRP products
Treadwell Products:	EX-Series® GratEX® GRP Square Mesh Grating & Stair Treads EXduro™ GRP Cable Ladders EX-Series® RailEX® ROUND GRP Handrails ArchitEX™ GRP Structural Profiles

Western Australia – This solar salt plant is part of a group of three sites that is the world’s largest exporter of seaborne salt, with the capacity to produce approximately 10.3 million tonnes every year. Natural energy from the sun and wind is harnessed for sale production.

Treadwell was engaged to supply the GRP grating and cable management systems for this salt mine.



Treadwell's Solution:

- Constructed from premium resin systems, Treadwell's GRP products are corrosion resistant, with fire retardant properties, as well as UV inhibitors, making it ideal for this outdoor and corrosive environment.
- Treadwell's unique surface finishing system ensures UV stability in exposed applications, directly eliminating the need for costly surface treatments.
- GRP is manufactured from a more economically sound raw material base than metallic alternatives, and is far more structurally sound when compared to timber and plastic materials.



Queensland - Mineral Processing Plant

What is EX-Series® LadderEX® GRP Ladders?

LadderEX® is the superior alternative to metallic ladders and cage systems, providing excellent corrosion resistance and electrical transparency. Even in complete immersion applications, Treadwell's fibreglass ladders have outlasted aluminium and steel, and required little or no maintenance.

Our products in this range are made from superior fibreglass which offers unparalleled advantages, leaving behind alternatives that are metal or steel based. Our ladders and ladder cage systems are produced using a premium grade polyester resin system with flame retardant and ultraviolet (UV) inhibitor additives. A vinyl ester resin system is available upon request for additional corrosion resistance. Standard side rails and cages are in safety yellow. The rungs are a pultruded fibreglass polyester tube with a fluted, non-skid surface.

LadderEX® fibreglass ladder systems are fabricated and designed with GRP according to AS 1657-2018. The pultruded parts are produced with a fire retardant polyester resin which meets the ASTM E-84 test for flame spread of 25 or less and contains a UV inhibitor. The colour is in standard OSHA safety yellow though colour matching can be provided.

Ladders are shop assembled and may be pre-drilled and prepared for field attachment with standoff clips and/ or base brackets systems.

The LadderEX® product range can easily be integrated into any existing platform or structure. It can come in a variety of configurations to suit any purpose as well.



LadderEX® Standard Ladder with ROUND Grab Stiles

LDX-RG

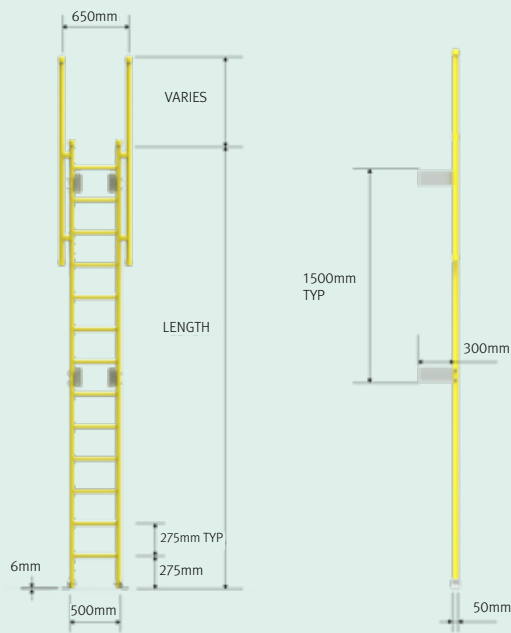

Brief:
In instances where there is a requirement for extra security above 1.5m, Treadwell can supply standard access ladders without returns with a round grab stile.

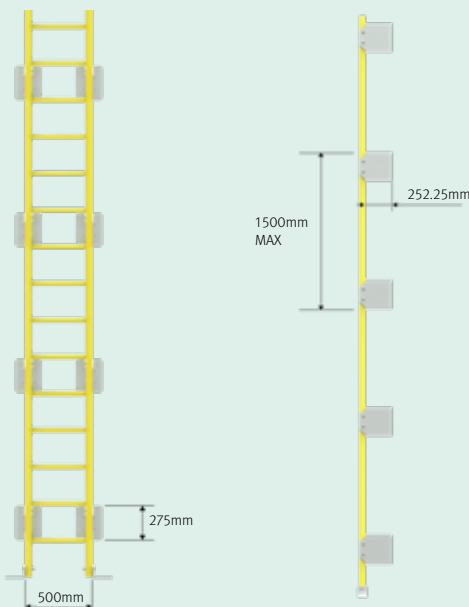

Please consult our LadderEX® Product Guide for more information.

LadderEX® Heavy Duty Wall Mounted SQUARE Ladder	LDX-SL
	
<p>Brief: For industrial and other heavy duty purposes, Treadwell supplies a more durable and robust heavy duty wall mount and floor mounts (if required) for that added safety factor.</p>	

RETRACT-A-STILES

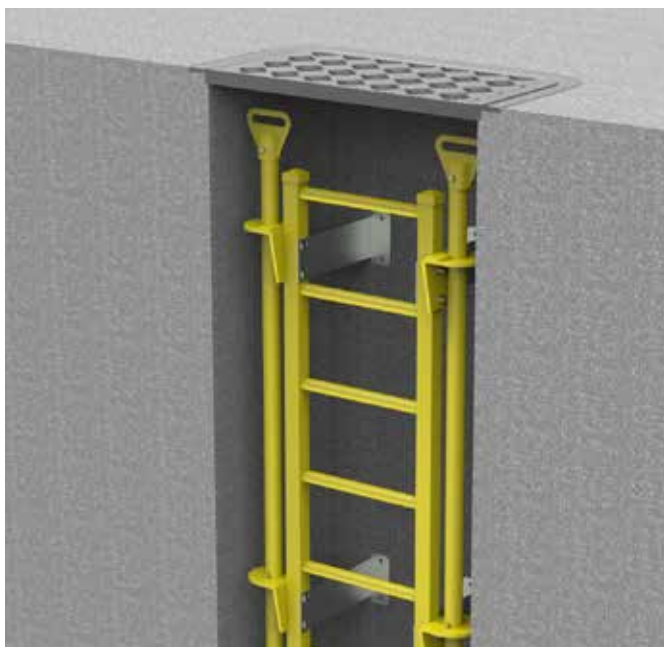

What are LadderEX® Retract-A-Stiles?

LadderEX® Retract-A-Stiles offer convenience, flexibility, and enhanced safety, especially in confined spaces. Constructed from corrosion-resistant GRP, they require minimal maintenance. Easy to install, they ensure safety at heights with ergonomically designed handles for superior grip and robust fixing brackets for strength and versatility.

LadderEX® components are modular, allowing numerous ladder and access configurations to meet specific site requirements. We can easily integrate your needs into any Retract-A-Stile design.

To comply with AS 1657 standards, ladders must be at least 1700mm long, with stiles extending at least 1000mm above the top landing. The gap between ground level and the first rung should be no less than 90% of the spacing between other rungs.

While Treadwell strives to ensure compliance with AS 1657, bespoke solutions may sometimes result in non-compliant products. In these cases, client approval to proceed is considered consent to supply non-compliant goods or services.

TREADSAFE™
Industrial Anti-Slip Solutions

Anti-Slip Safety Solutions

TREADSAFE™ is Treadwell's selection of pre-manufactured and ready made for installation anti-slip products for harsh environments.

Fabricated from GRP composites, anti-slip decks and rung covers are easy to install over existing stairs to create the toughest and most dependable anti-slip surface available.

Proven in many applications, the series is available in various styles and colours to suit any environment.



StairSAFE™

Long wearing, anti-corrosive, non-slip nosing designed to re-profile the leading edge of any step are the characteristics of StairSAFE™.



CableSAFE™

CableSAFE™ creates a safe walkway over exposed pipes, cables, wires and conduit. With a durable anti-slip surface, CableSAFE™ provides a safety bridge for foot traffic over these areas, avoiding slips, trips and falls.



RungSAFE™

The abrasive grit surface eliminates the very high possibility of slips from access ladders, avoiding serious ramifications. The surface, while ideal for the negation of slip issues, has been developed so as not to damage bare skin.



DeckSAFE™

DeckSAFE™ is the ultimate solution for slippery ramps, decks, catwalks and landings. Designed to reduce the risk of slips, trips and falls in areas where oil, water and other forms of liquids are present, DeckSAFE™ greatly reduces risks.

EASY INSTALLATION

Heavy duty industrial fixings for all applications. Surface for rungs normally applied by using a polyurethane adhesive glue system.



OPTIONAL DEPTH AND LENGTH

Available in four standard depths, 50mm, 75mm, 100mm and 300mm. Custom depths are also available up to 300mm. Available in any length up to 3,250mm.

SAFETY

Heavy duty grit layer provides an ideal anti-slip surface; likewise, safety yellow offers enhanced visibility.

CHEMICAL RESISTANT

Designed to handle most chemicals. Please refer to our Chemical Resistance Guide, found in our TREADSAFE™ Product Guide.

ZERO TRIP RISK

Smooth bullnose, sloped on an 85° inclined plane ensures no trip risk is posed.

ROBUST CONSTRUCTION

Specially formulated resin systems and metallic available on request.

ArchitEX™
Structural Profiles & Structures

Composite Structural GRP

The ArchitEX™ range of products comprises of a variety of structural profiles that are manufactured from Glass Reinforced Plastic (GRP). It is through continual research and development that this wide range of fibreglass sections, beams, and profiles are fabricated consistently to ensure satisfactory results even in challenging structural conditions.

The GRP beams, columns and associated sections are produced from high quality GRP material, which makes structures strong as well as rewarding. Durable construction GRP such as fibreglass sections and beams enhances the strength of the entire framework as well as infrastructure. Both fibreglass beams and sections are specifically designed to endure all sorts of environmental inconsistencies.



Scope of Shapes

Easy integration to various parts due to the capability to essentially shape any item with a constant cross section which can be pultruded.

Composite Design Engineering

A standard shape customised into a pultrusion by modifying the resin or reinforcement to achieve a particular customer need.

Optimising Resins

Standard resins can be modified or special resins can be used to maximise performance of the pultrusion in challenging environments, such as those found in high temperature or extremely corrosive areas. Typical resins include polyesters, vinylesters, PVC, epoxies, phenolics, urethanes and blends.

Choice of Reinforcements

The type, form, placement and quantity of reinforcements can be customised to optimise economy, develop ascribed strength and create or enhance other physical characteristics of a pultruded part. Typical reinforcements used include glass or carbon fibres in multifilament strands, mat (long fibres held together with a resinous binder) or stitched fabrics.

Core Materials Options

Treadwell provides a range of core material options with comprehensive experience in pultruding over various materials including foam, balsa, polyethylene and aluminium.

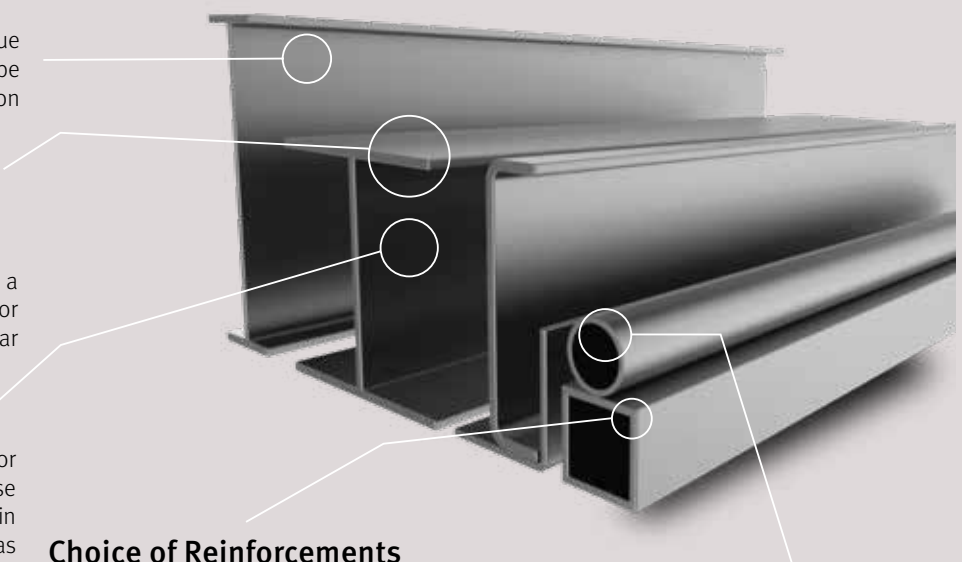









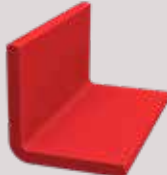

Structural Design & Analysis

Our experienced team of engineers and designers can help conceptualise your design and maximise all GRP structural components to offer the most cost effective and simplest solution.

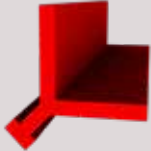

ArchitEX™ GRP Profiles

ArchitEX™ Range		
C Channel	I-Beam	WF-Beam
		
Double Web Beam	Unequal Leg Angle	Equal Leg Angle
		
Square Hollow Section	Rectangular Hollow Section	Circular Hollow Section
		
Circular Round Bar	Solid Bars	Embedment Angle
		

Please consult our ArchitEX™ Structural Product Guide for more information.



TreadSLAB® Panel Types Available

TreadSLAB®

TreadSLAB® is an immensely versatile profile which combines lightweight and inherent strength to provide a durable product with a variety of surface textures and a customisable range of colours. Through the selection of the appropriate resin system, the user can create components that will meet the most demanding of specifications.

Pultruded through a die, TreadSLAB® outperforms with an impressive strength to weight ratio to produce a composite flooring structure that is strong, durable, corrosion resistant and boasts low maintenance on an anti-slip surface.

Benefits

- High strength
- Light weight
- Dimensional stability
- Corrosion, chemical, electrical resistance
- Low tooling/installation cost
- Long life
- Favourable performance/lifecycle cost basis versus traditional materials

TreadSLAB® easily outperforms traditional materials in terms of performance/ lifecycle costs.

Part: TreadSLAB® Medium Duty Panel

Part Number: **ARX-SL040**

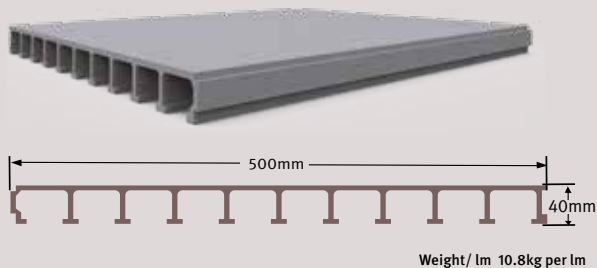

Part: TreadSLAB® Heavy Duty Panel

Part Number: **ARX-SL100**

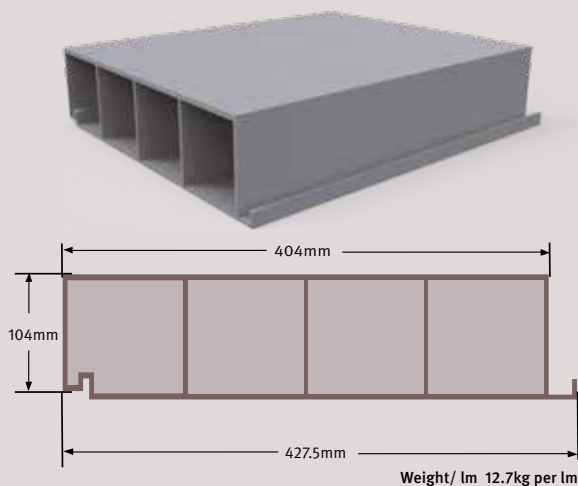

Case Study – Purlin Replacement



PROJECT INFORMATION	
Project Category:	Structural Infrastructure
Scope of Work:	Supply GRP structural profiles
Treadwell Products:	ArchitEX™ GRP Structural Profiles

Our client represents the world’s largest integrated titanium dioxide project. As a vertically integrated producer of titanium dioxide and inorganic chemicals, this company mines and produces titanium related products, amongst others. Their products add brightness and durability to paints, plastics, paper and other everyday products.

The client needed the purlin replaced in one of their storage facilities. Treadwell was engaged to supply the GRP structural profiles, whilst design and engineer services were provided by an external party.



Treadwell's Solution:

- 1

ArchitEX™ GRP structural profiles are constructed from premium resin systems which ensure durability with built-in corrosion resistant properties.

- 2

Treadwell’s GRP is naturally non-conductive which provide electrical safety.

- 3

GRP is simply fabricated and modified on site. This means there is no need for any hot works permit.

- 4

Being lightweight and easy to install, GRP is very manageable during construction.

- 5

Given the nature of GRP, any system utilizing it is virtually maintenance free, keeping maintenance costs to a minimum.

Our Partners





Strathalbyn, South Australia - Factory & Warehouse



Material Availability

We have established extensive stockholdings internationally, ready to be fabricated or shipped according to your project requirements. With offices and warehouses located throughout the APAC and UK regions, shipments can be quickly arranged.

Our in-house design and engineering teams have exceptional CAD capabilities. Our factory features top of the range automated CNC equipment allowing project requirements to be quickly fulfilled.

Strathalbyn, South Australia - Factory & Warehouse

United Kingdom

ABERDEEN (OFFICE)

- ▶ UNIT F8, ENTERPRISE CENTRE
ABERDEEN ENERGY PARK
AB238GX

New Zealand

NORTH ISLAND

▶ (OFFICE & WAREHOUSE)

36 RATANUI STREET AORANGI,
FEIDLING 4775

Australia

SOUTH AUSTRALIA

▶ ADELAIDE (HEAD OFFICE & WAREHOUSE)

58 DEEDS ROAD
NORTH PLYMPTON, SA 5037

▶ STRATHALBYN (FACTORY & WAREHOUSE)

22 DUNREATH ROAD
STRATHALBYN, SA 5255

VICTORIA

▶ GEELONG (SERVICED OFFICE)

33 MACKEY ST,
NORTH GEELONG, VIC 3215

NEW SOUTH WALES

▶ SYDNEY (SERVICED OFFICE)

SUITE 13D, 21 SYDNEY ROAD
MANLY, NSW 2095

▶ WAGGA (BRANCH OFFICE & WAREHOUSE)

13 CHESHIRE ST,
WAGGA WAGGA, NSW 2650

QUEENSLAND

▶ BRISBANE (SERVICED OFFICE)

SHOP 1, LEVEL 1, TOOWONG VILLAGE,
9 SHERWOOD RD, TOOWONG, QLD 4066

WESTERN AUSTRALIA

▶ PERTH (BRANCH OFFICE & WAREHOUSE)

3 RUNYON ROAD,
MIDVALE, WA 6056

TASMANIA

▶ BURNIE (DISTRIBUTION CENTRE)

28-30 BRICKPORT ROAD
COOEE, TAS 7320

